

PROPOSED 18.5m R.O.W.

LEGEND

- CONCRETE PAVING
- PEDESTRIAN UNIT PAVING A - LIGHT GREY
- PEDESTRIAN UNIT PAVING A - DARK GREY
- PEDESTRIAN UNIT PAVING B
- VEHICULAR UNIT PAVING
- MULCH
- SOD
- BIKE RACKS
- BENCH
- DOG RUN FENCE
- TREE GRATE
- FEATURED PLANTING
- TREE PLANTING

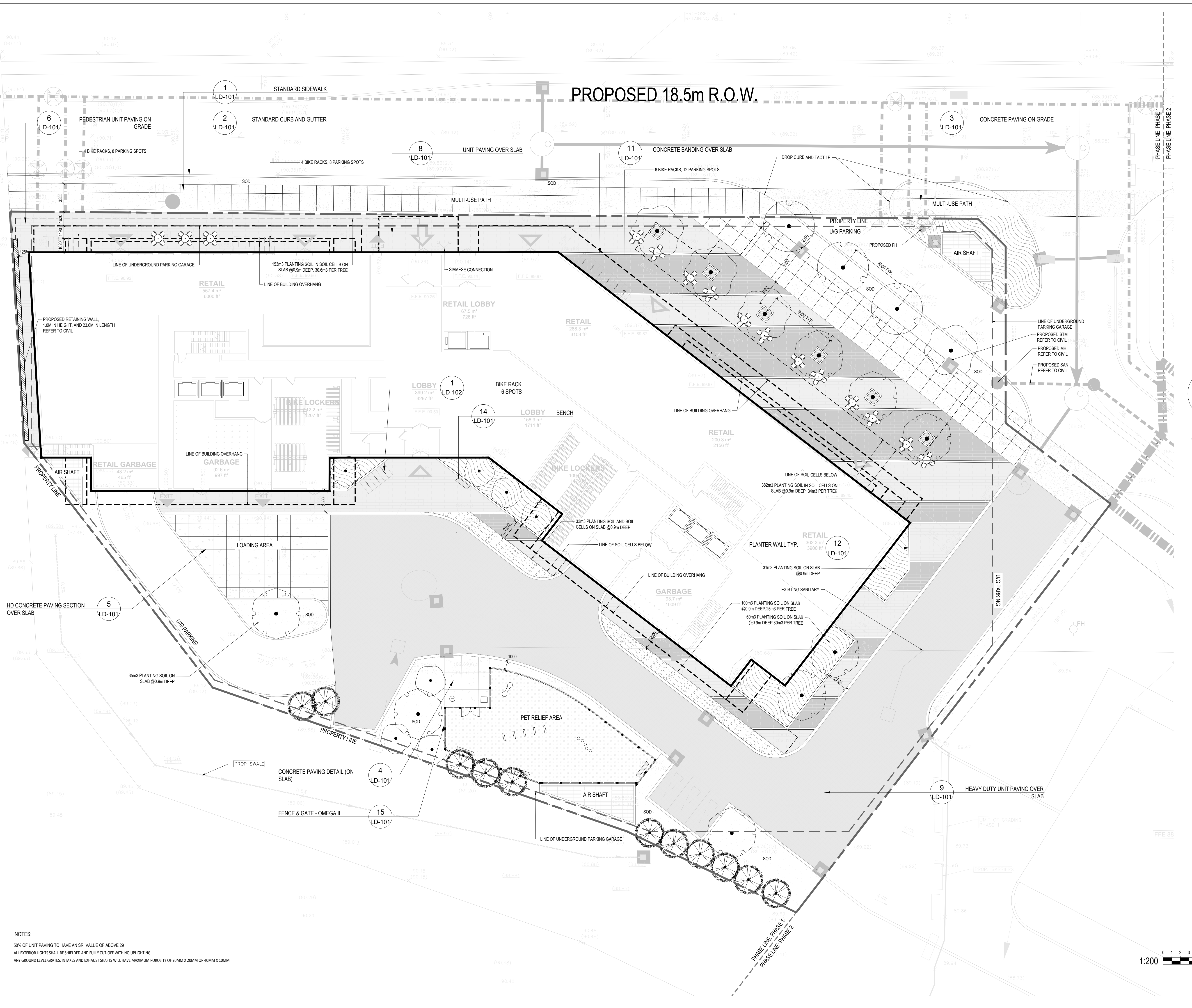

NOTES:
 50% OF UNIT PAVING TO HAVE AN SRI VALUE OF ABOVE 29
 ALL EXTERIOR LIGHTS SHALL BE SHIELDED AND FULLY CUT-OFF WITH NO UPLIGHTING
 ANY GROUND LEVEL GRATES, INTAKES AND EXHAUST SHAFTS WILL HAVE MAXIMUM POROSITY OF 20MM X 20MM OR 40MM X 10MM

no.	revision	date	by
3	ISSUED FOR ZBA	2025-01-31	RR
2	ISSUED FOR ZBA	2025-01-16	RR
1	ISSUED FOR ZBA	2022-05-06	RR

CONTRACTOR MUST VERIFY ALL DIMENSIONS ON THE JOB AND REPORT ANY DISCREPANCY TO THE LANDSCAPE ARCHITECT BEFORE PROCEEDING WITH THE WORK.
 ALL DRAWINGS AND SPECIFICATIONS ARE INSTRUMENTS OF SERVICE AND THE PROPERTY OF THE LANDSCAPE ARCHITECT WHICH MUST BE RETURNED AT THE COMPLETION OF THE WORK.
 ALL DRAWINGS TO BE USED FOR CONSTRUCTION ONLY WHEN SIGNED BY THE LANDSCAPE ARCHITECT.

signed _____ date _____



20 Champlain Blvd. Suite 102 - Toronto ON - M3H 2Z1 info@studioa.ca www.studioa.ca

CLIENT
 1755 PICKERING PARKWAY
 PICKERING, ONTARIO

PROJECT
 LANDSCAPE PLAN

DRAWING
 DRAWN: RR
 CHECKED:
 SCALE: AS SHOWN
 DATE: 2021-03-01
 PROJECT NO.: 20-175



SHEET NO.: LS-100

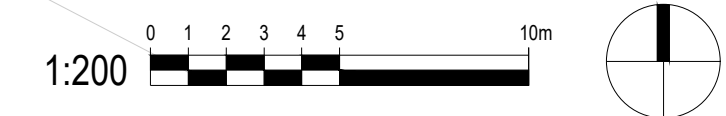

January 31, 2025 2:22 PM I:\01-PROJECTS\2025\01-1755-PICKERING-PARKWAY-PICKERING-DESIGN-CENTRE\01-CA\01-CURRENT\TPO\01-SPAZ\01-TS-100-LANDSCAPE-PLAN.DWG

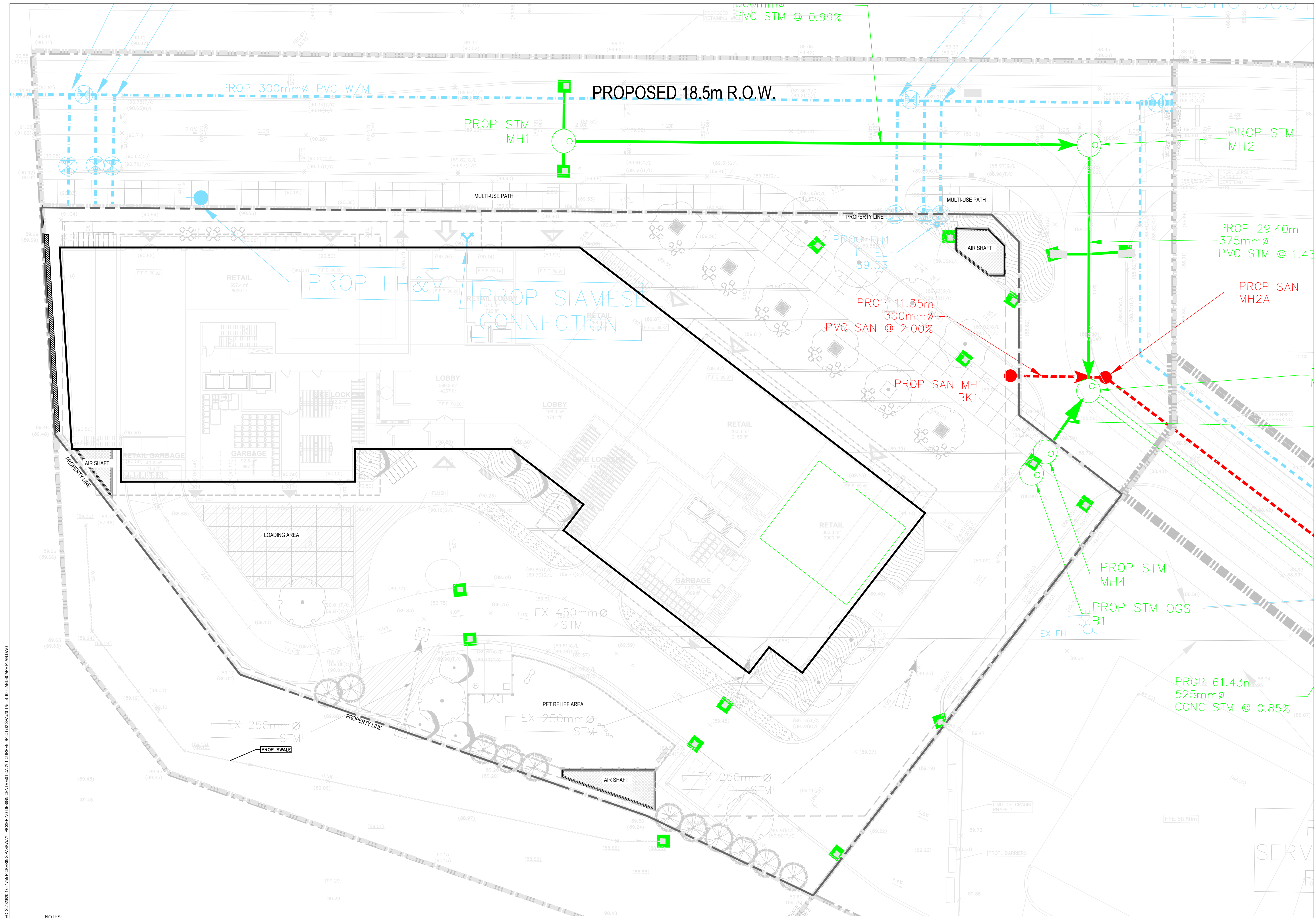

no.	revision	date	by
3	ISSUED FOR ZBA	2025-01-31	RR
2	ISSUED FOR ZBA	2025-01-16	RR
1	ISSUED FOR ZBA	2022-05-06	RR

CONTRACTOR MUST VERIFY ALL DIMENSIONS ON THE JOB AND REPORT ANY DISCREPANCY TO THE LANDSCAPE ARCHITECT BEFORE PROCEEDING WITH THE WORK. ALL DRAWINGS AND SPECIFICATIONS ARE INSTRUMENTS OF SERVICE AND THE PROPERTY OF THE LANDSCAPE ARCHITECT WHICH MUST BE RETURNED AT THE COMPLETION OF THE WORK. ALL DRAWINGS TO BE USED FOR CONSTRUCTION ONLY WHEN SIGNED BY THE LANDSCAPE ARCHITECT.

signed _____ date _____

STUDIO t1a
 20 Champian Blvd. Suite 102 - Toronto ON - M3H 2Z1 info@studiola.ca www.studiola.ca

CLIENT: 1755 PICKERING PARKWAY
 PICKERING, ONTARIO
 PROJECT: COMPOSITE UTILITY PLAN

DRAWING: RR
 CHECKED: AS SHOWN
 DATE: 2021-03-01
 PROJECT NO: 20-175





SHEET NO.: LS-101

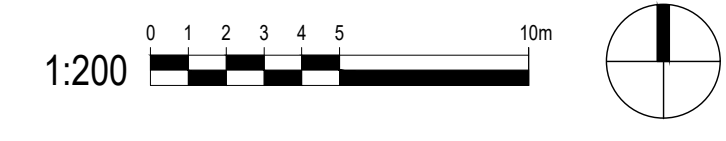

January 31, 2025 2:22 PM I:\01-PROJECTS\2020\01-1755 PICKERING PARKWAY - PICKERING DESIGN CENTRE\01-CA\01-CURRENT\01-01-01-01-01 LANDSCAPE PLAN DWG

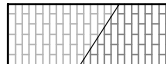
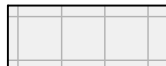
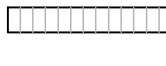
NOTES:
 50% OF UNIT PAVING TO HAVE AN SRI VALUE OF ABOVE 29
 ALL EXTERIOR LIGHTS SHALL BE SHIELDED AND FULLY CUT-OFF WITH NO UPLIGHTING
 ANY GROUND LEVEL GRATES, INTAKES AND EXHAUST SHAFTS WILL HAVE MAXIMUM POROSITY OF 20MM X 20MM OR 40MM X 10MM



- LEGEND
-  PEDESTRIAN UNIT PAVING A
 -  PEDESTRIAN UNIT PAVING B
 -  UNIT PAVER BANDING
 -  PLANTING AREA
 -  2M HT. ACOUSTIC BARRIER
 -  PLANTER
 -  ORNAMENTAL TREE

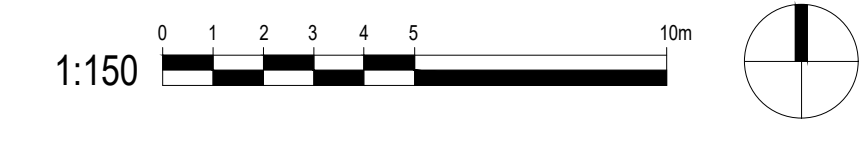
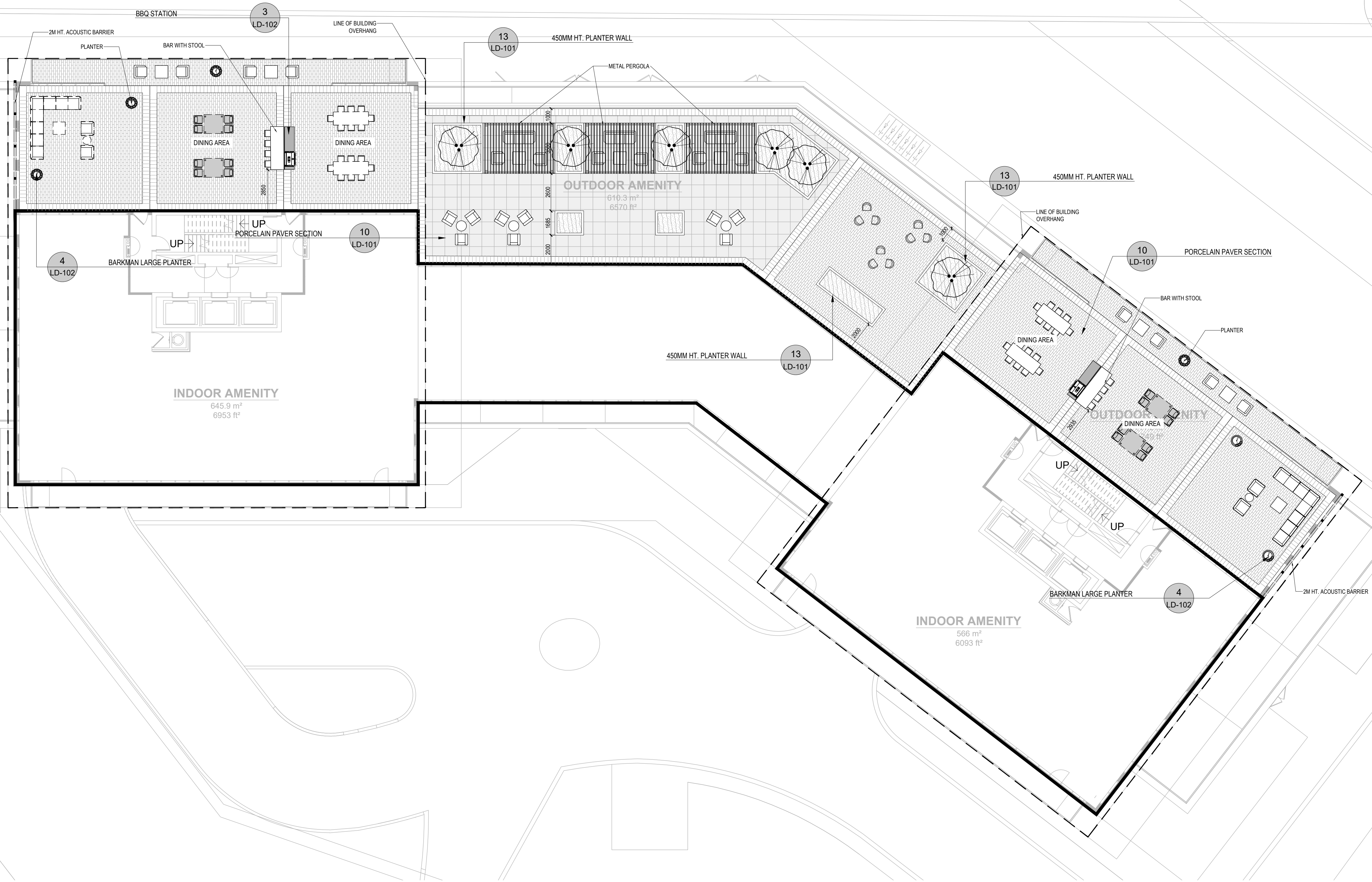

no.	revision	date	by
3	ISSUED FOR ZBA	2025-01-31	RR
2	ISSUED FOR ZBA	2025-01-16	RR
1	ISSUED FOR ZBA	2022-05-06	RR

CONTRACTOR MUST VERIFY ALL DIMENSIONS ON THE JOB AND REPORT ANY DISCREPANCY TO THE LANDSCAPE ARCHITECT BEFORE PROCEEDING WITH THE WORK. ALL DRAWINGS AND SPECIFICATIONS ARE INSTRUMENTS OF SERVICE AND THE PROPERTY OF THE LANDSCAPE ARCHITECT WHICH MUST BE RETURNED AT THE COMPLETION OF THE WORK. ALL DRAWINGS TO BE USED FOR CONSTRUCTION ONLY WHEN SIGNED BY THE LANDSCAPE ARCHITECT.

signed _____ date _____

STUDIO tla
 20 Champlain Blvd. Suite 102 - Toronto ON - M3H 2Z1 | info@studiotla.ca | www.studiotla.ca

CLIENT: 1755 PICKERING PARKWAY
 PICKERING, ONTARIO
 PROJECT: 7TH FLOOR LANDSCAPE PLAN

DRAWING: RR
 CHECKED: AS SHOWN
 DATE: 2021-03-01
 PROJECT NO.: 20-175



SHEET NO.: LS-200

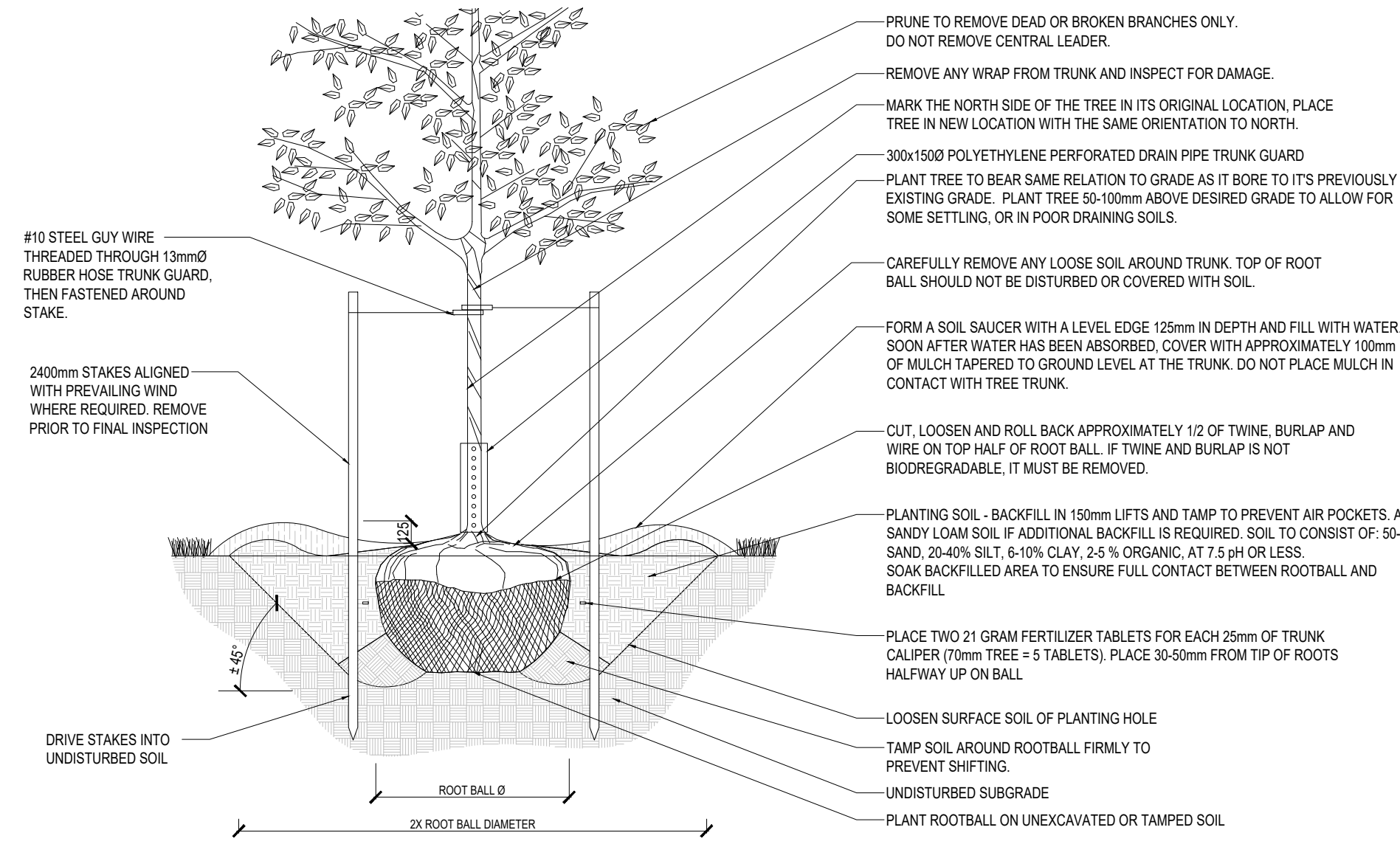

1 STAKED B&B DECIDUOUS TREE INSTALLATION DETAIL
SCALE=NO SCALE

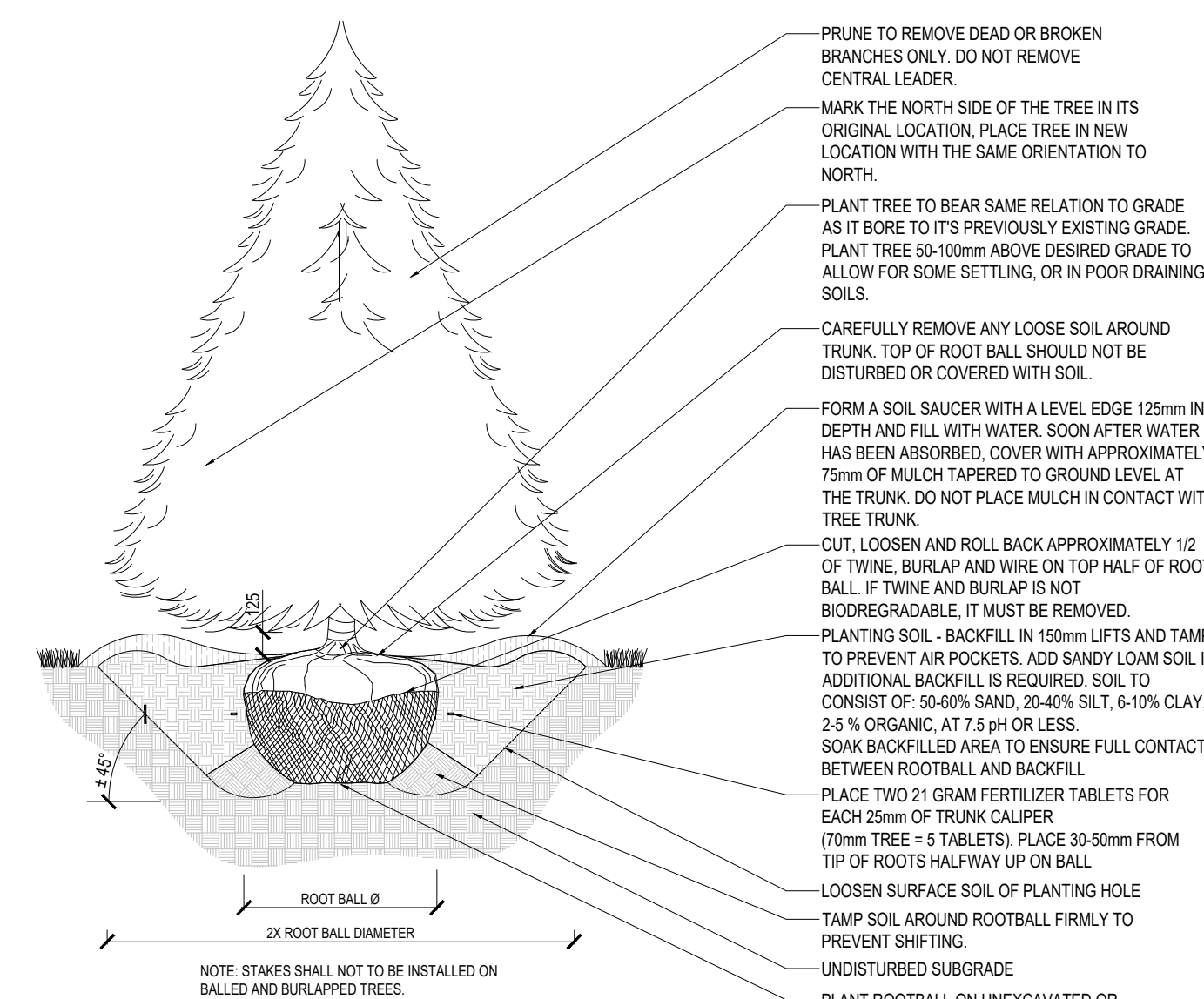

2 B&B CONIFEROUS TREE PLANTING DETAIL
NO SCALE

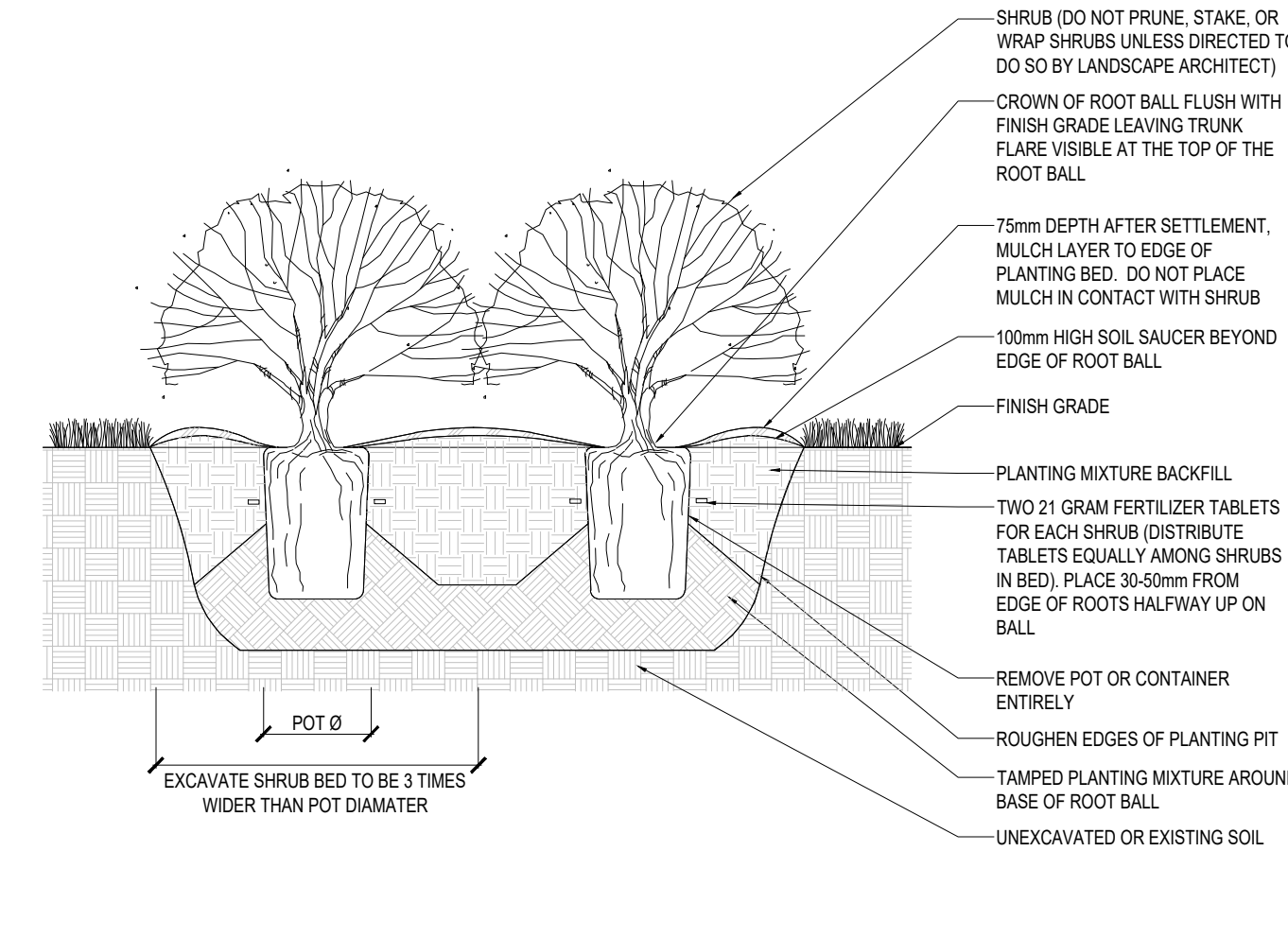

3 POTTED SHRUB BED PLANTING DETAIL
NO SCALE

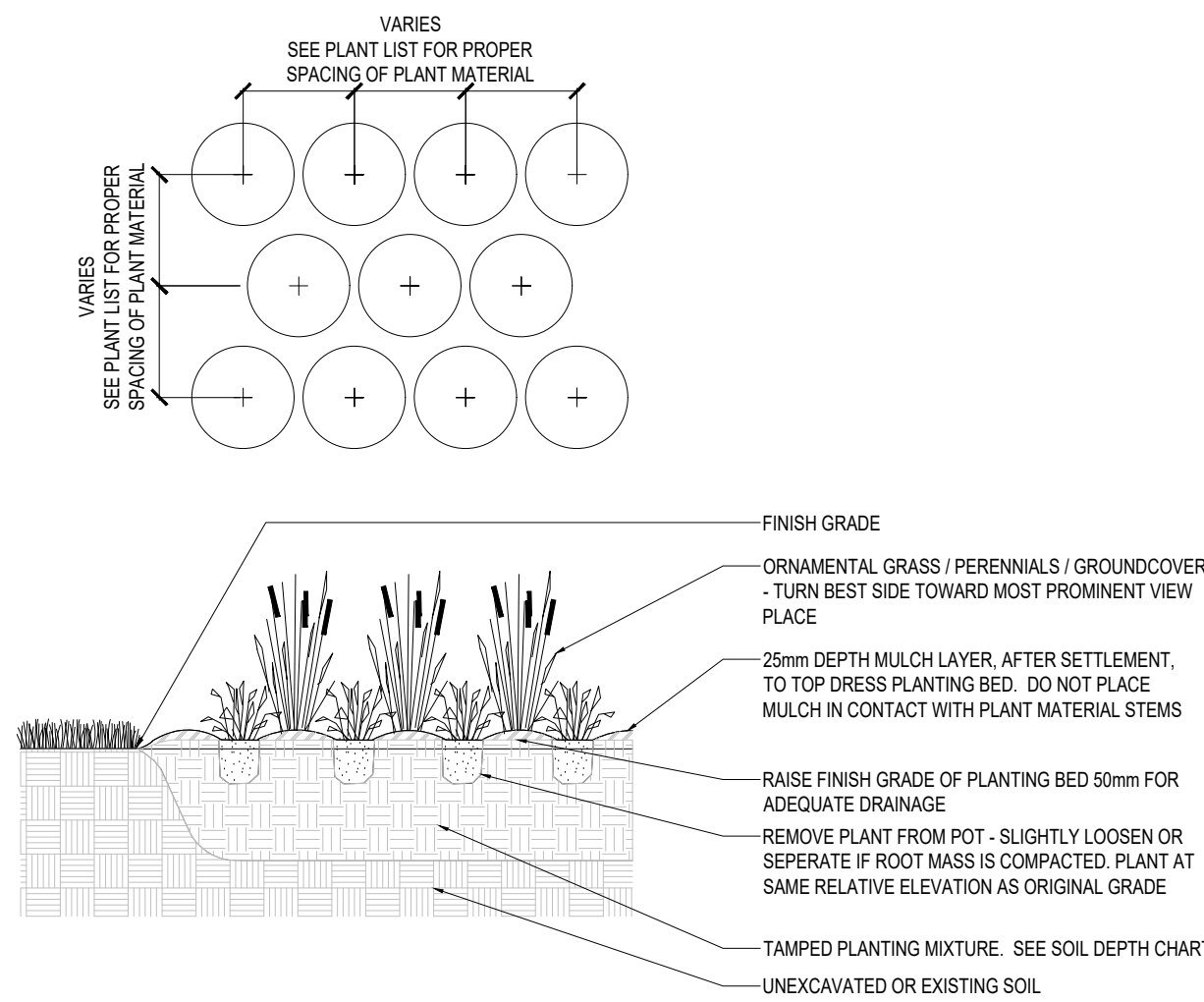

4 GROUNDCOVER PLANTING DETAIL
NO SCALE

NOTE: THE CONTRACTOR IS TO SUPPLY TOPSOIL FILL MATERIAL TO THE DEPTHS INDICATED ON THE CHART BELOW.

LANDSCAPE AREAS	DEPTH IN mm
LAWN AREAS (SOD)	150
LAWN AREAS (SEED)	150
PLANTING BEDS - GRASSES, PERENNIALS AND GROUND COVER	300
PLANTING BEDS - MEDIUM AND SMALL SHRUBS	450
RAISED PLANTERS	600
SHADE AND ORNAMENTAL TREES	PER TREE INSTALLATION DETAIL.
ON SLAB SHRUB PLANTING	600 WITH 150mm DRAINAGE GRAVEL

5 SOIL DEPTH MINIMUMS
NO SCALE

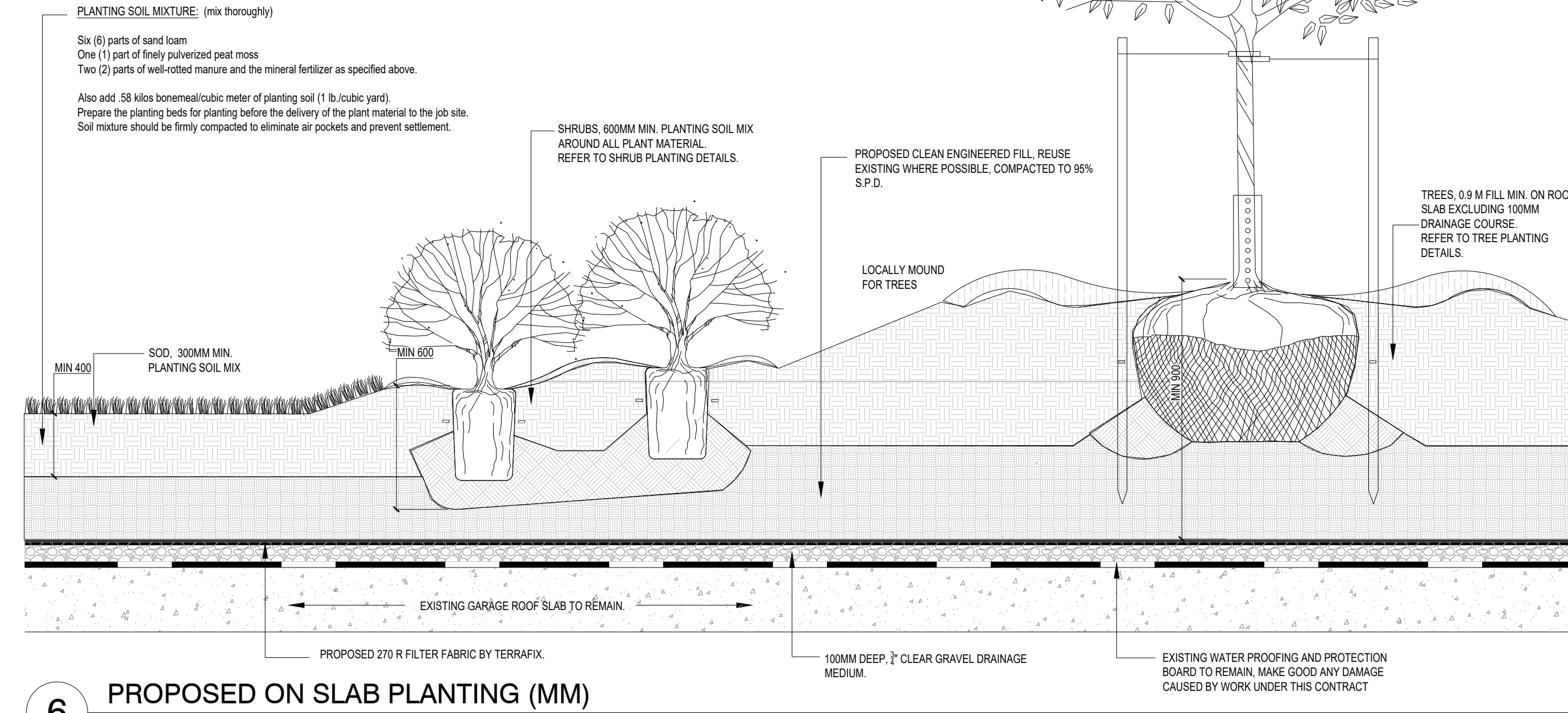

6 PROPOSED ON SLAB PLANTING (MM)
1:20

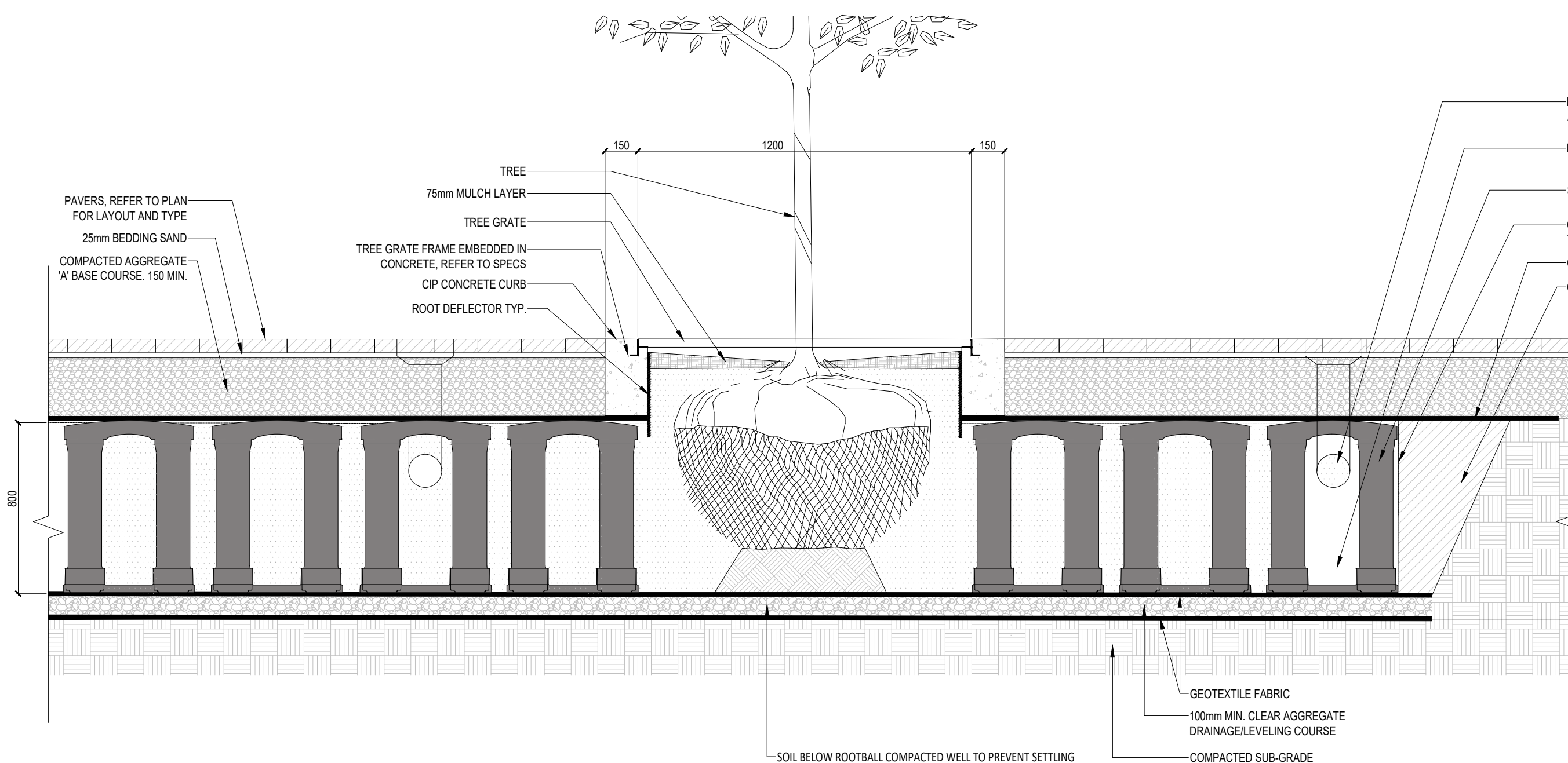

7 TREE PLANTING IN SOIL CELLS ON GRADE
SCALE = 1:20

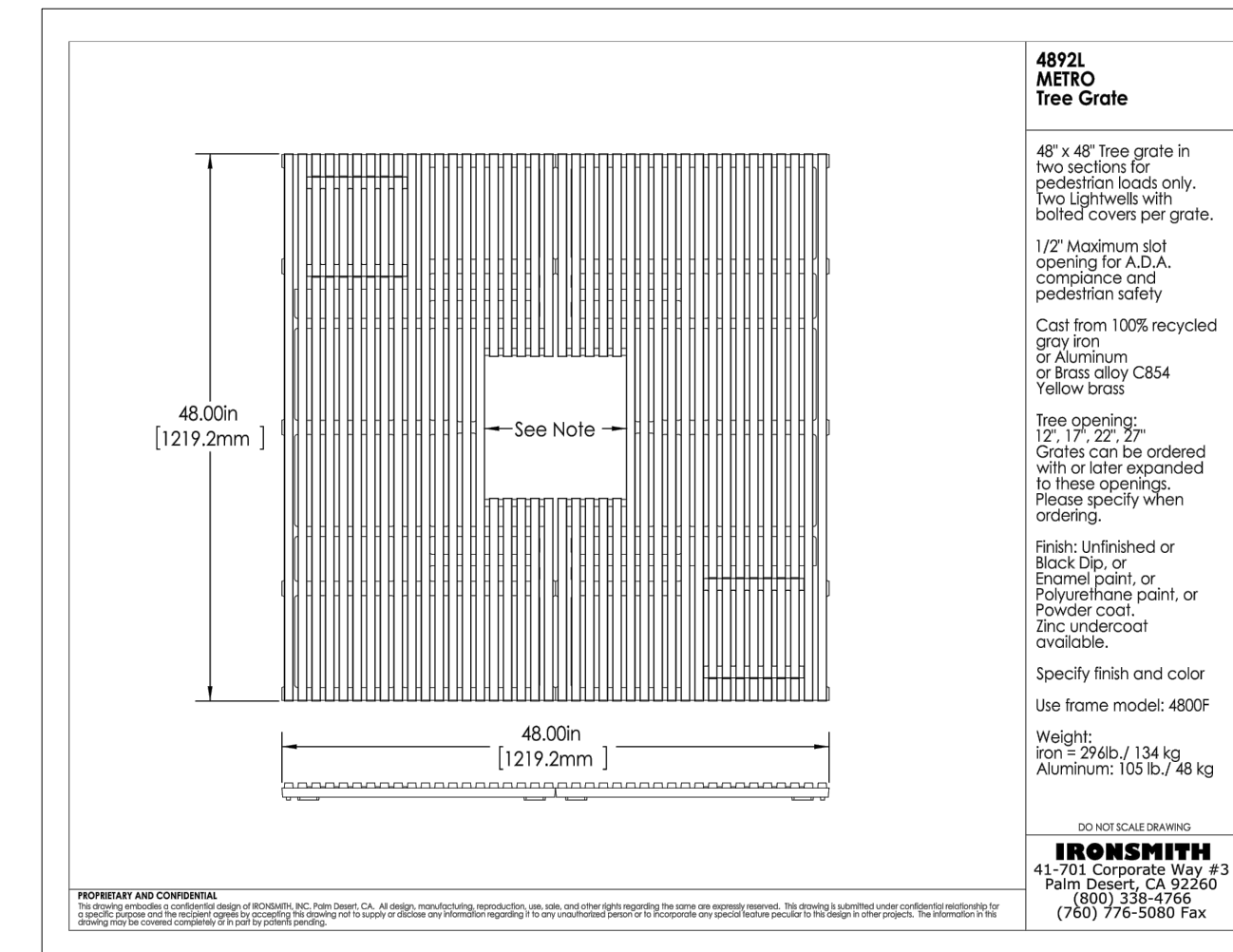

8 TREE GRATE
N.T.S.

no.	revision	date	by
3	ISSUED FOR ZBA	2025-01-31	RR
2	ISSUED FOR ZBA	2025-01-16	RR
1	ISSUED FOR ZBA	2022-05-06	RR

CONTRACTOR MUST VERIFY ALL DIMENSIONS ON THE JOB AND REPORT ANY DISCREPANCY TO THE LANDSCAPE ARCHITECT BEFORE PROCEEDING WITH THE WORK. ALL DRAWINGS AND SPECIFICATIONS ARE INSTRUMENTS OF SERVICE AND THE PROPERTY OF THE LANDSCAPE ARCHITECT WHICH MUST BE RETURNED AT THE COMPLETION OF THE WORK. ALL DRAWINGS TO BE USED FOR CONSTRUCTION ONLY WHEN SIGNED BY THE LANDSCAPE ARCHITECT.

signed _____ date _____

STUDIO tla

20 Champian Blvd. Suite 102 - Toronto ON - M3H 2Z1 info@studiola.ca www.studiola.ca

CLIENT

1755 PICKERING PARKWAY

PICKERING, ONTARIO

PROJECT

LANDSCAPE DETAILS

DRAWING

RR

CHECKED:

AS SHOWN

DATE: 2021-03-01

PROJECT NO: 20-175

DRAWN

RR

ASSOCIATION OF LANDSCAPE ARCHITECTS

MEMBER

LD-100

SHEET NO.

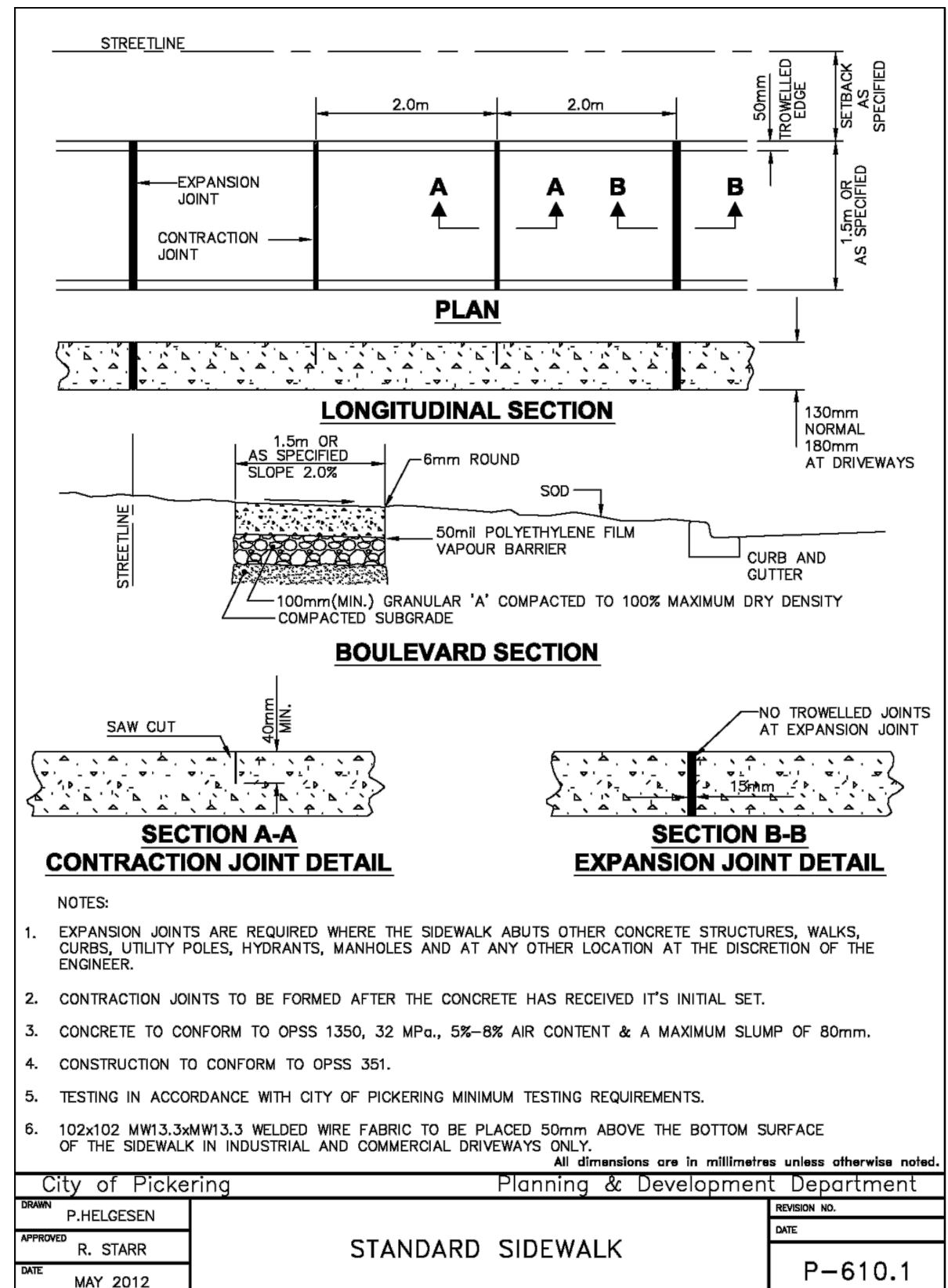

1 STANDARD SIDEWALK
N.T.S.

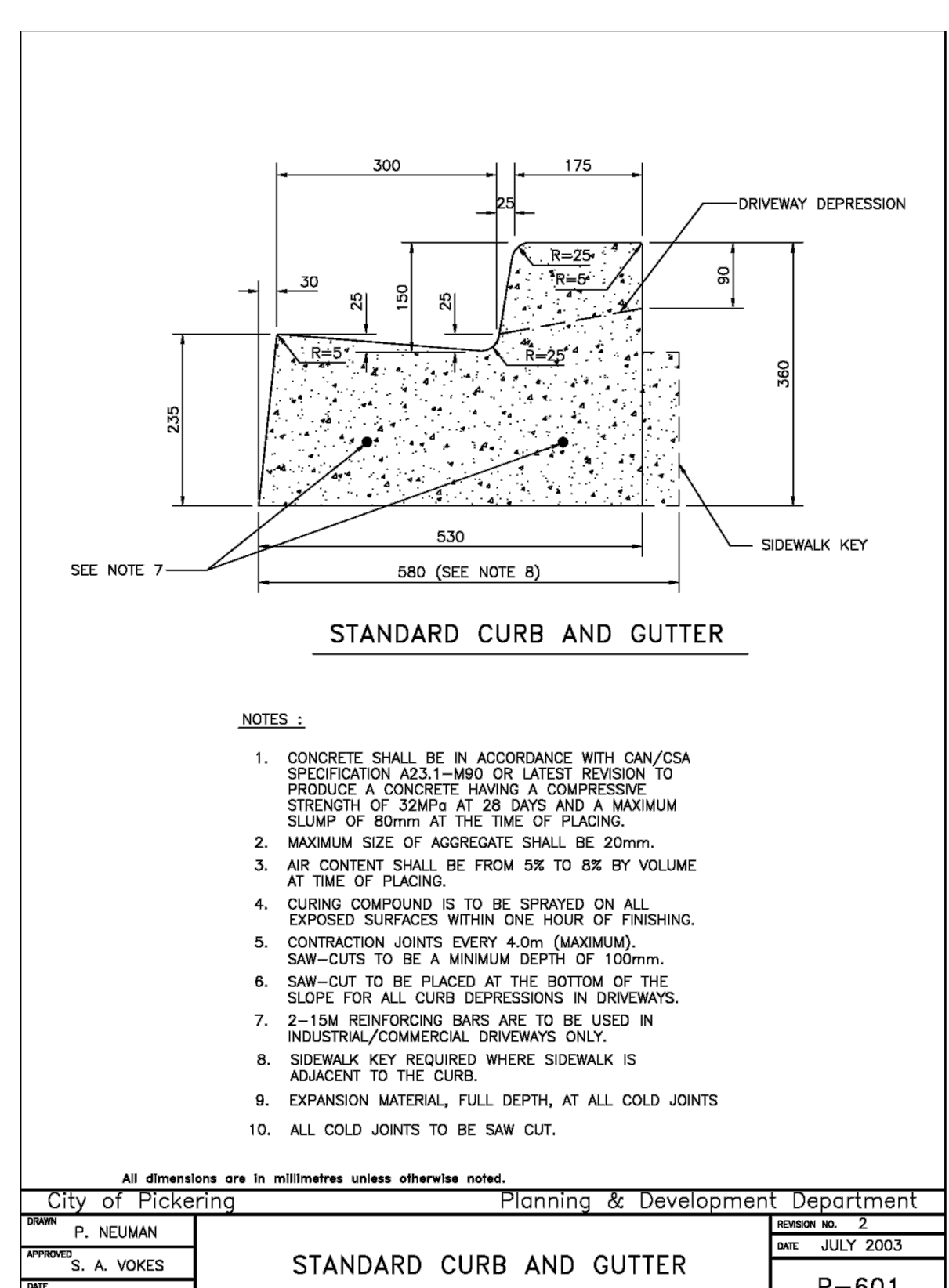

2 STANDARD CURB AND GUTTER
N.T.S.

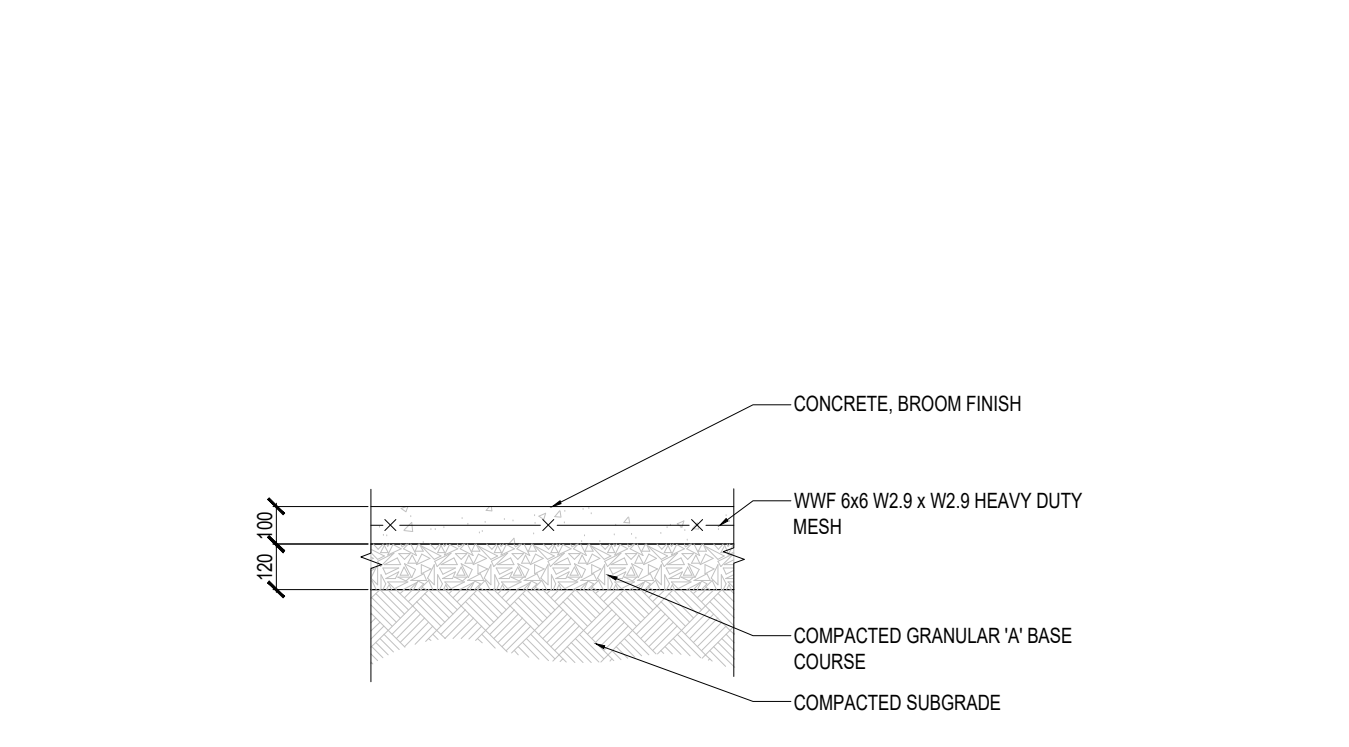

3 CONCRETE PAVING ON GRADE
SCALE: 1:20

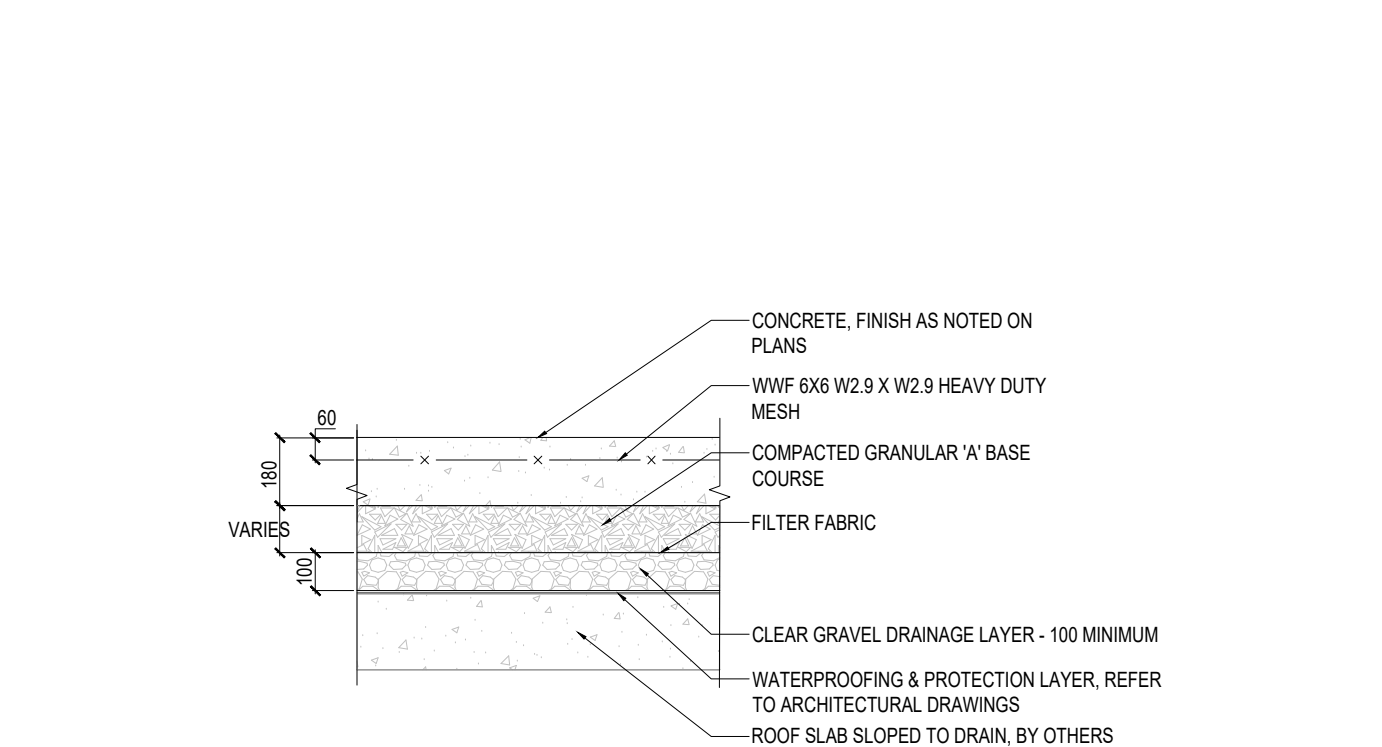

5 HD CONCRETE PAVING SECTION OVER SLAB
SCALE: 1:20

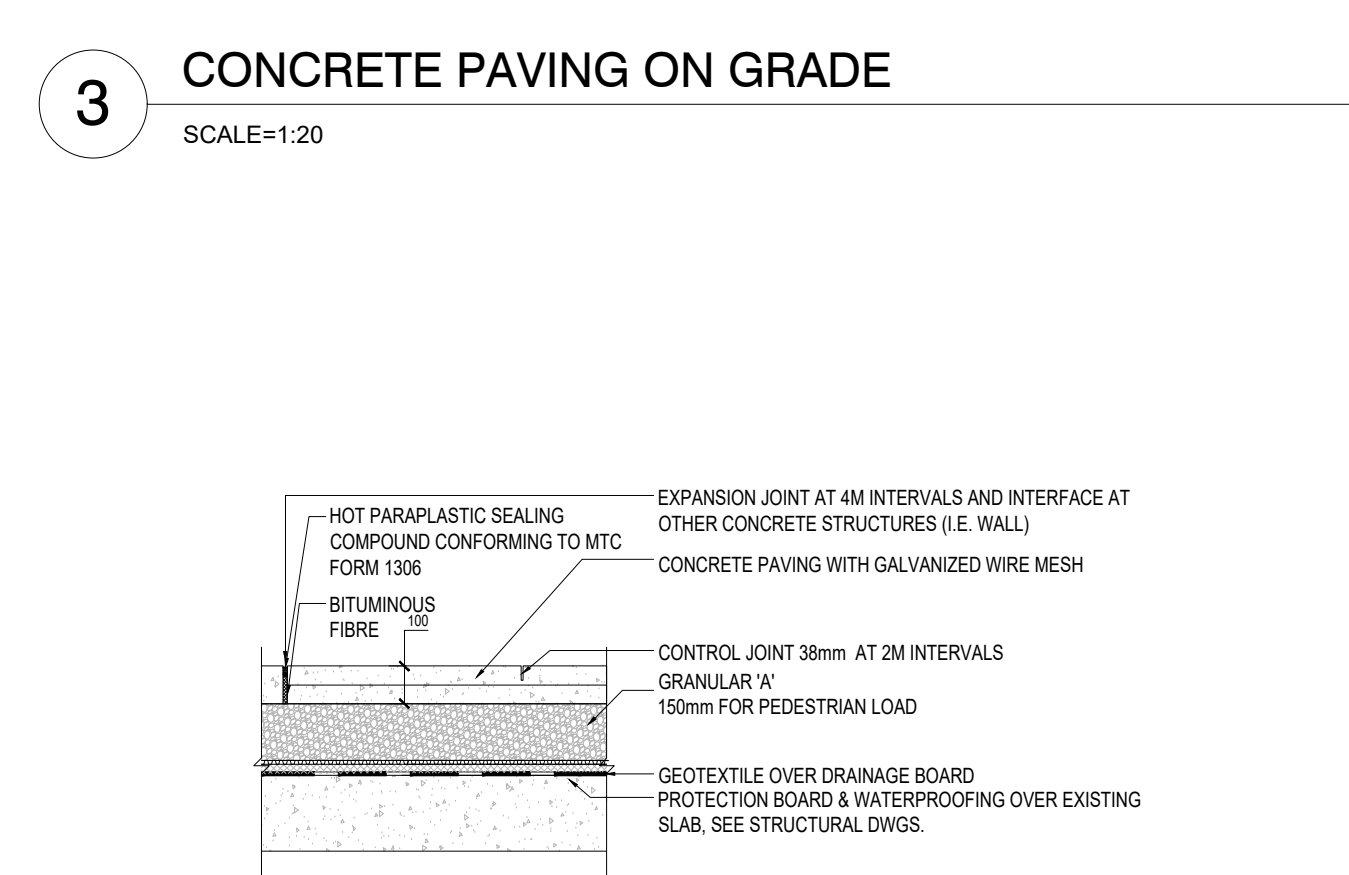

4 CONCRETE PAVING DETAIL (ON SLAB)
SCALE: 1:20

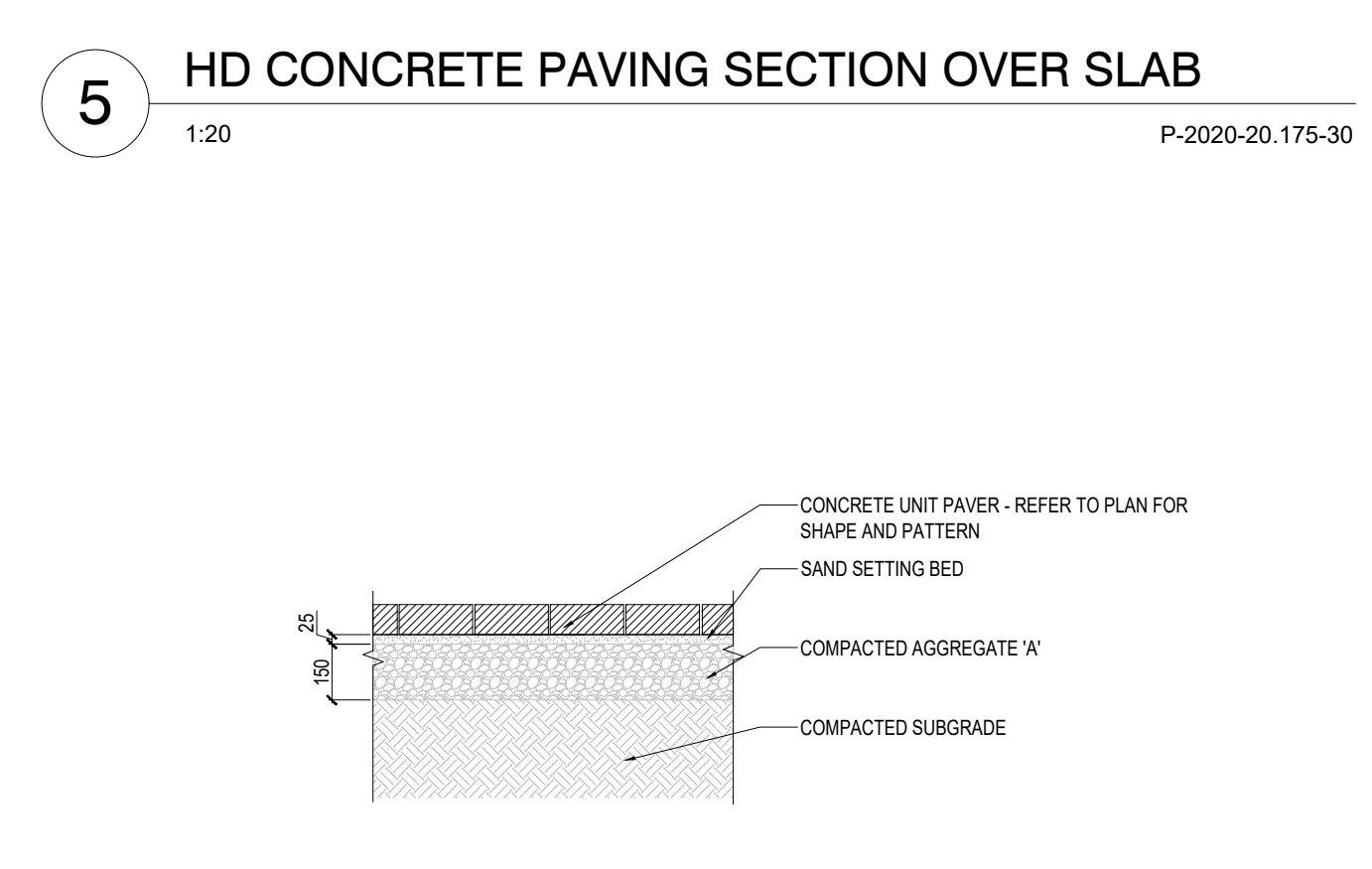

6 PEDESTRIAN UNIT PAVING ON GRADE
SCALE: 1:20

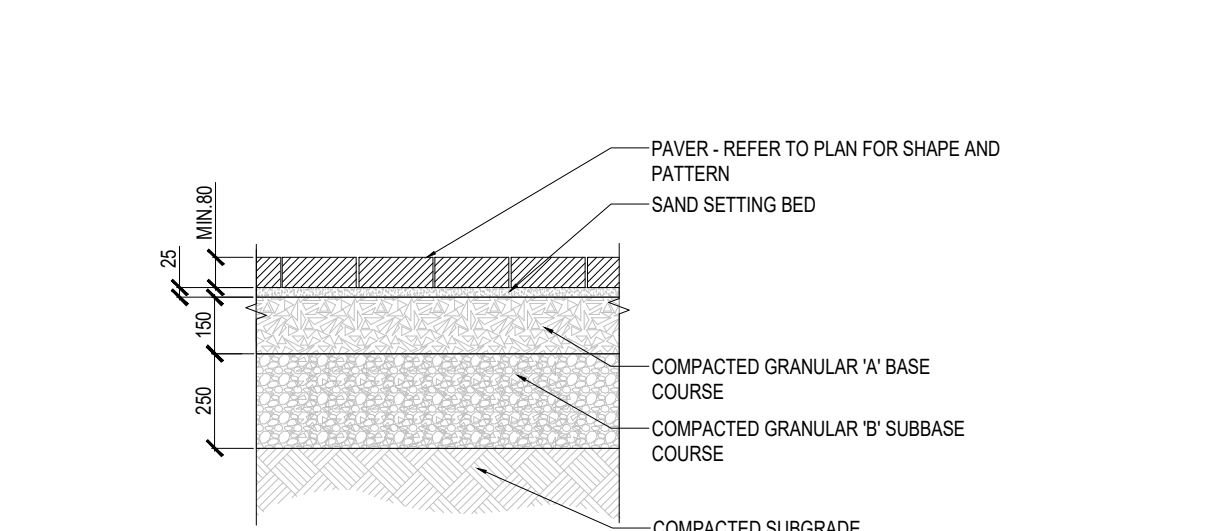

7 HEAVY DUTY PAVEMENT ON GRADE
SCALE: 1:20

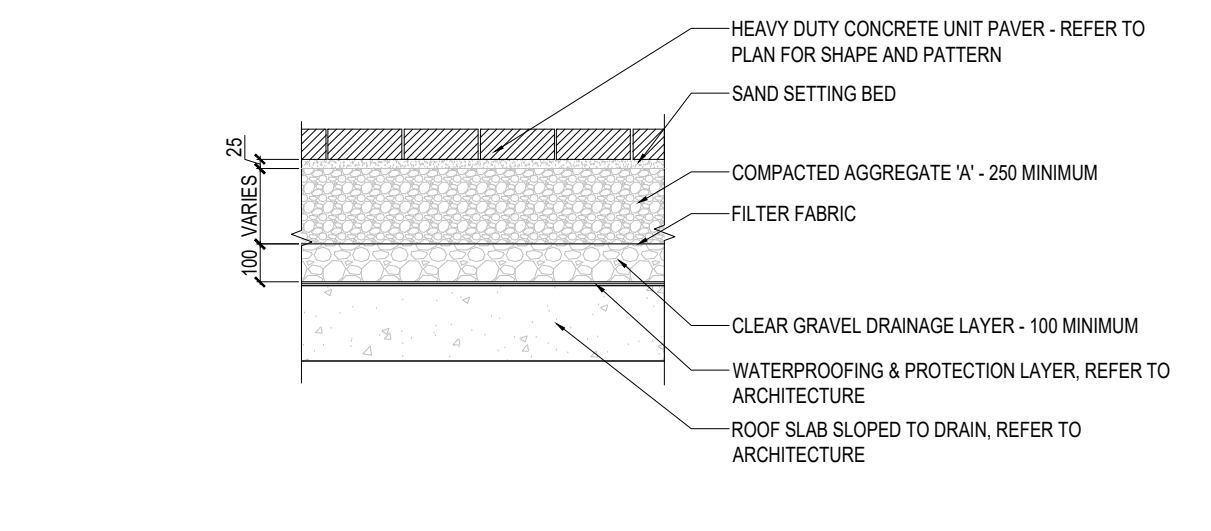

9 HEAVY DUTY UNIT PAVING OVER SLAB
SCALE: 1:20

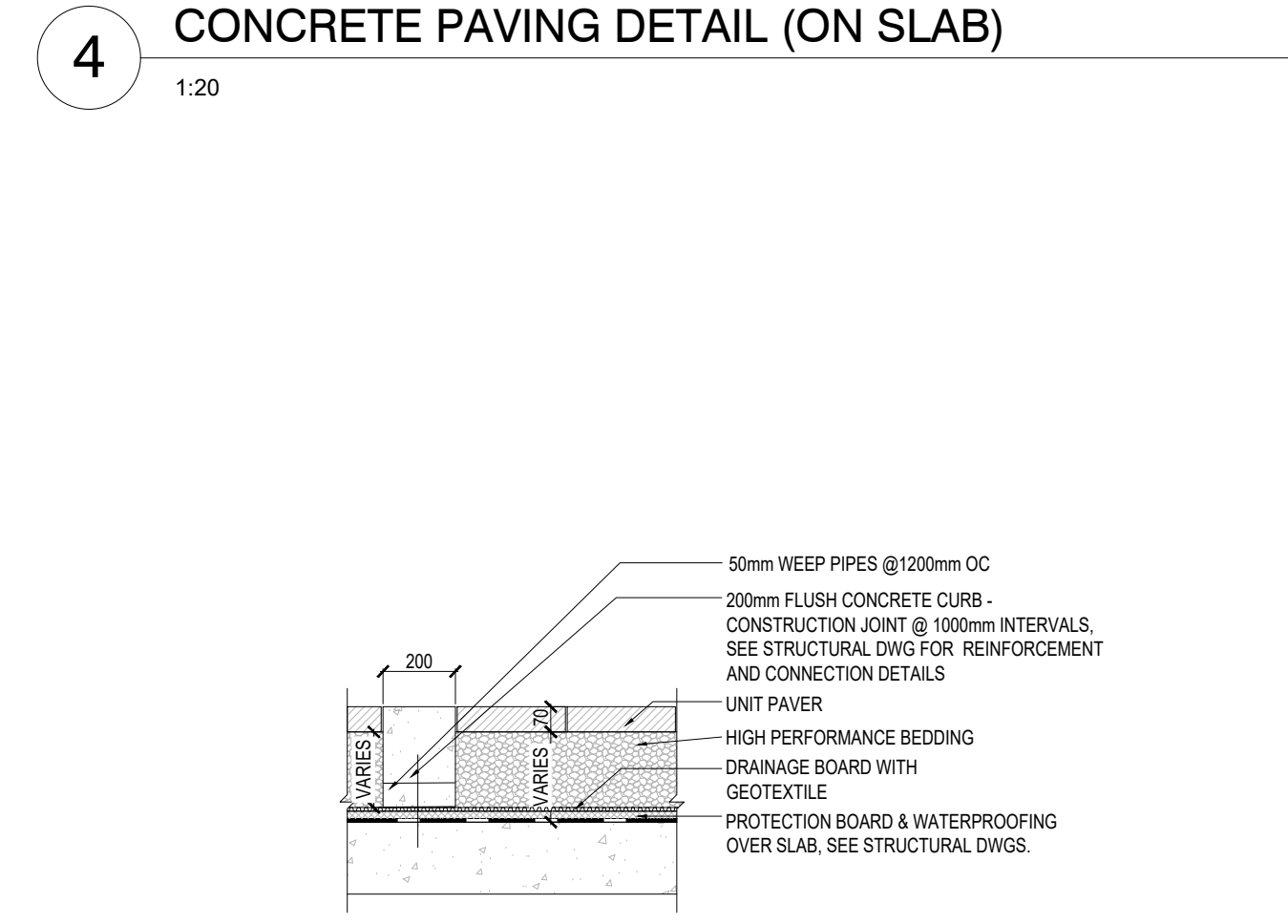

11 CONCRETE BANDING OVER SLAB
SCALE: 1:20

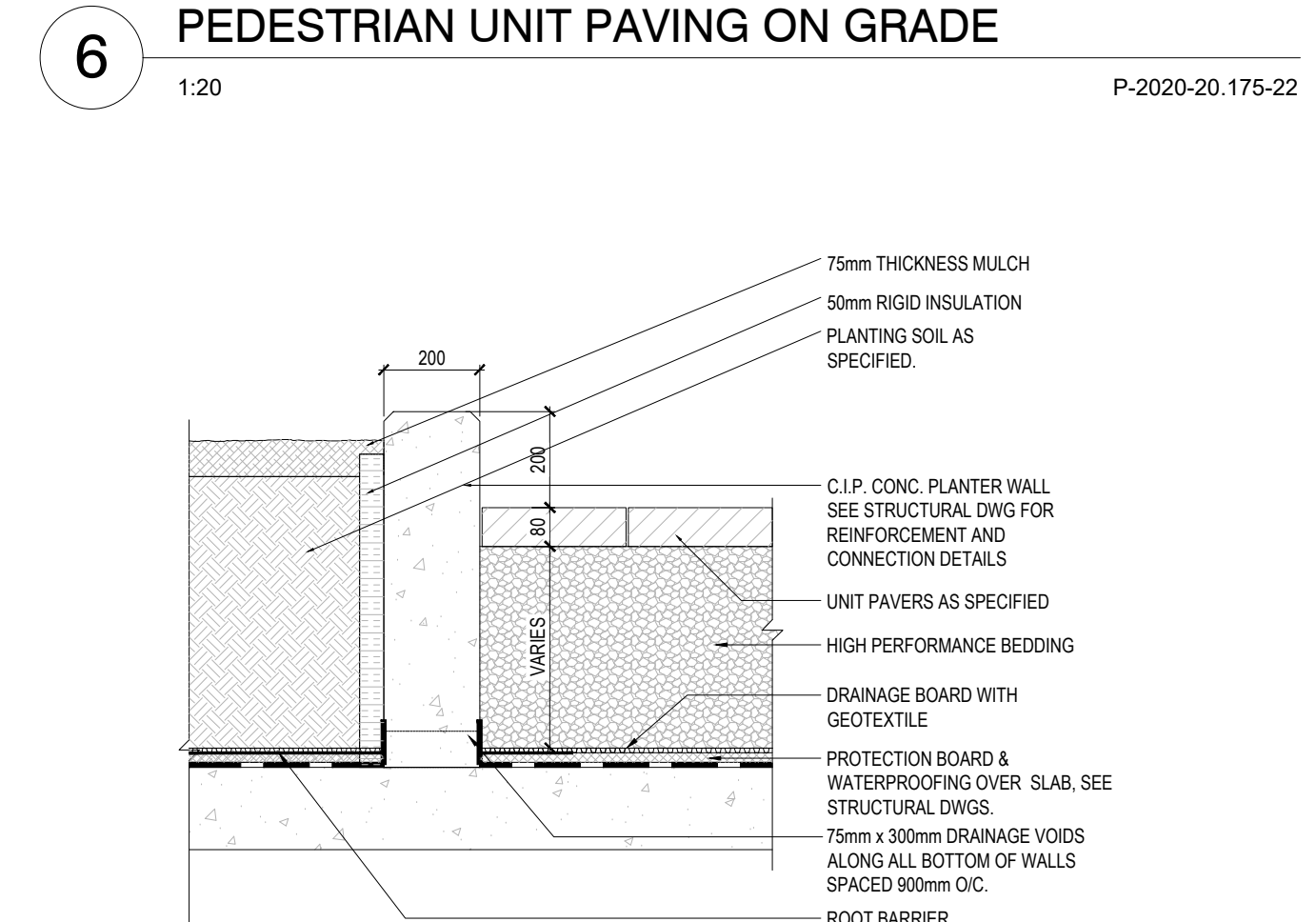

12 PLANTER WALL TYP.
SCALE: 1:15

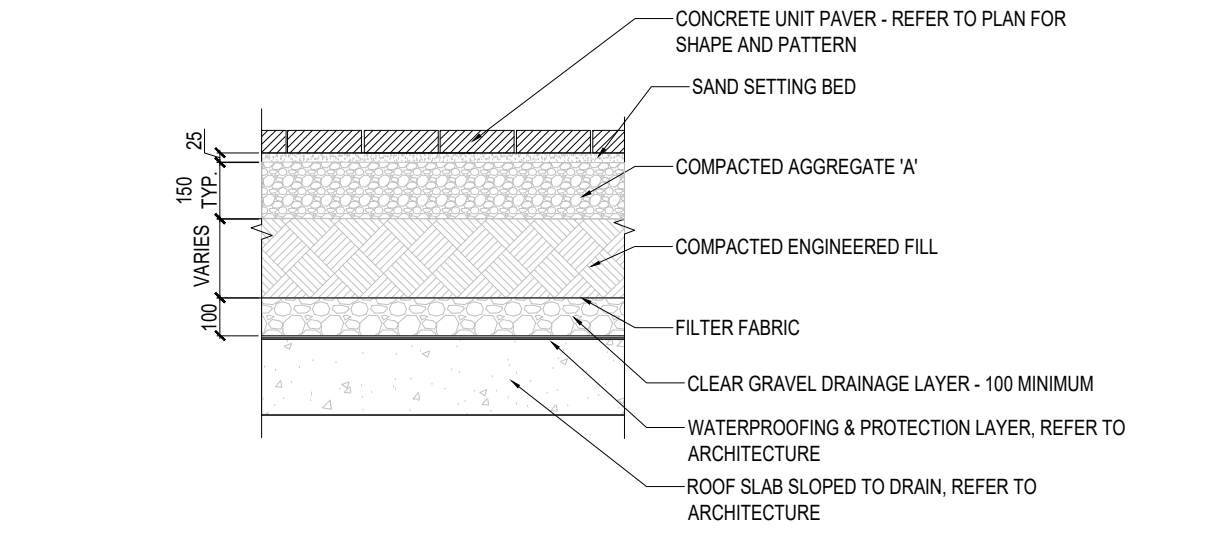

8 UNIT PAVING OVER SLAB
SCALE: 1:20

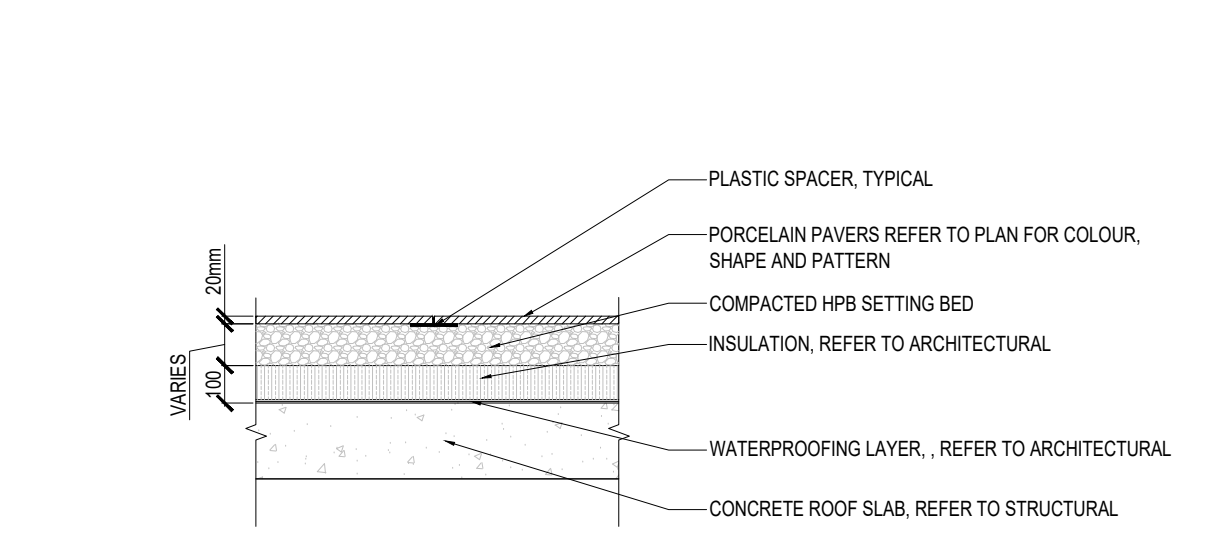

10 PORCELAIN PAVER SECTION
SCALE: 1:20

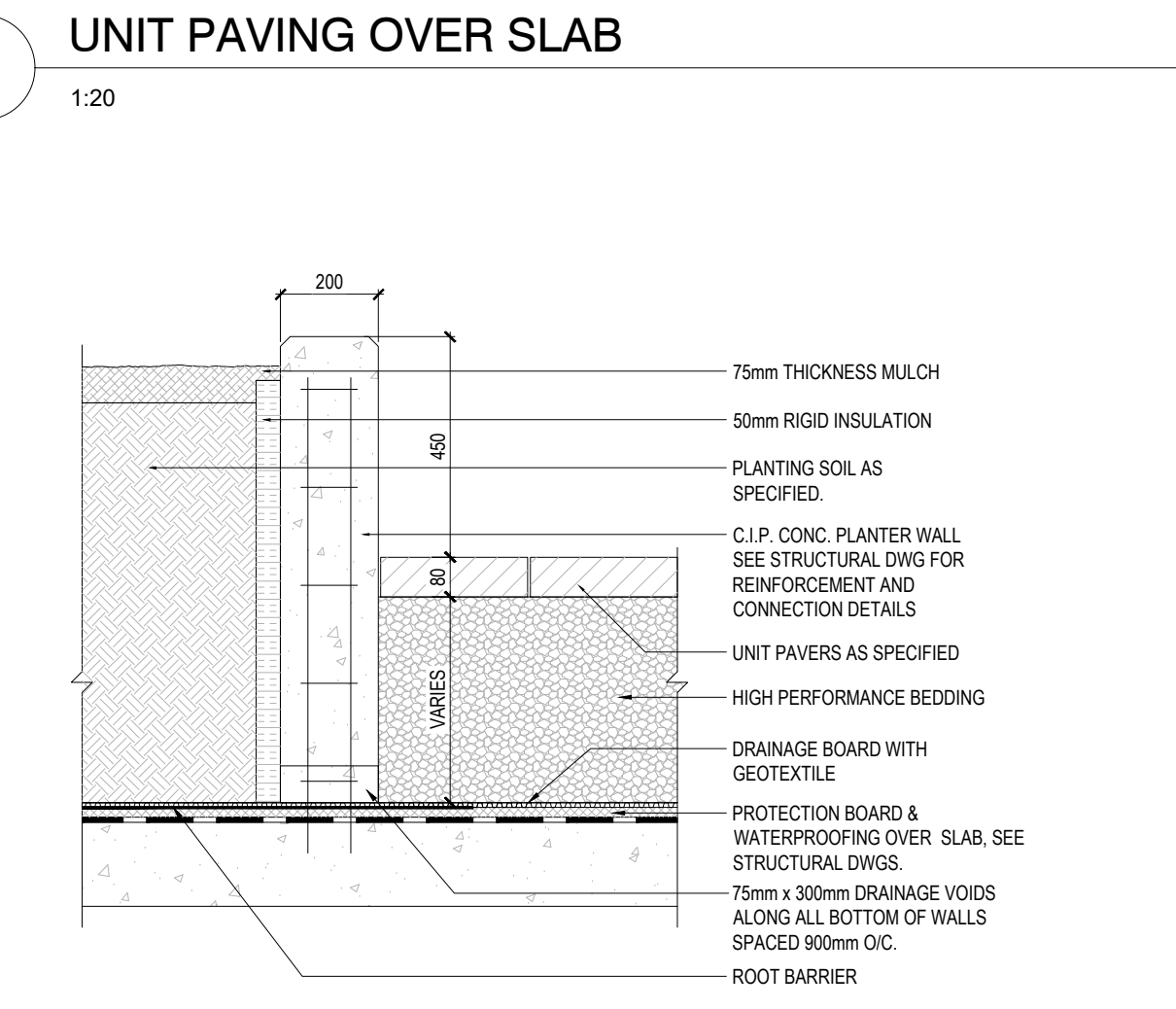

13 450MM HT. PLANTER WALL
SCALE: 1:15

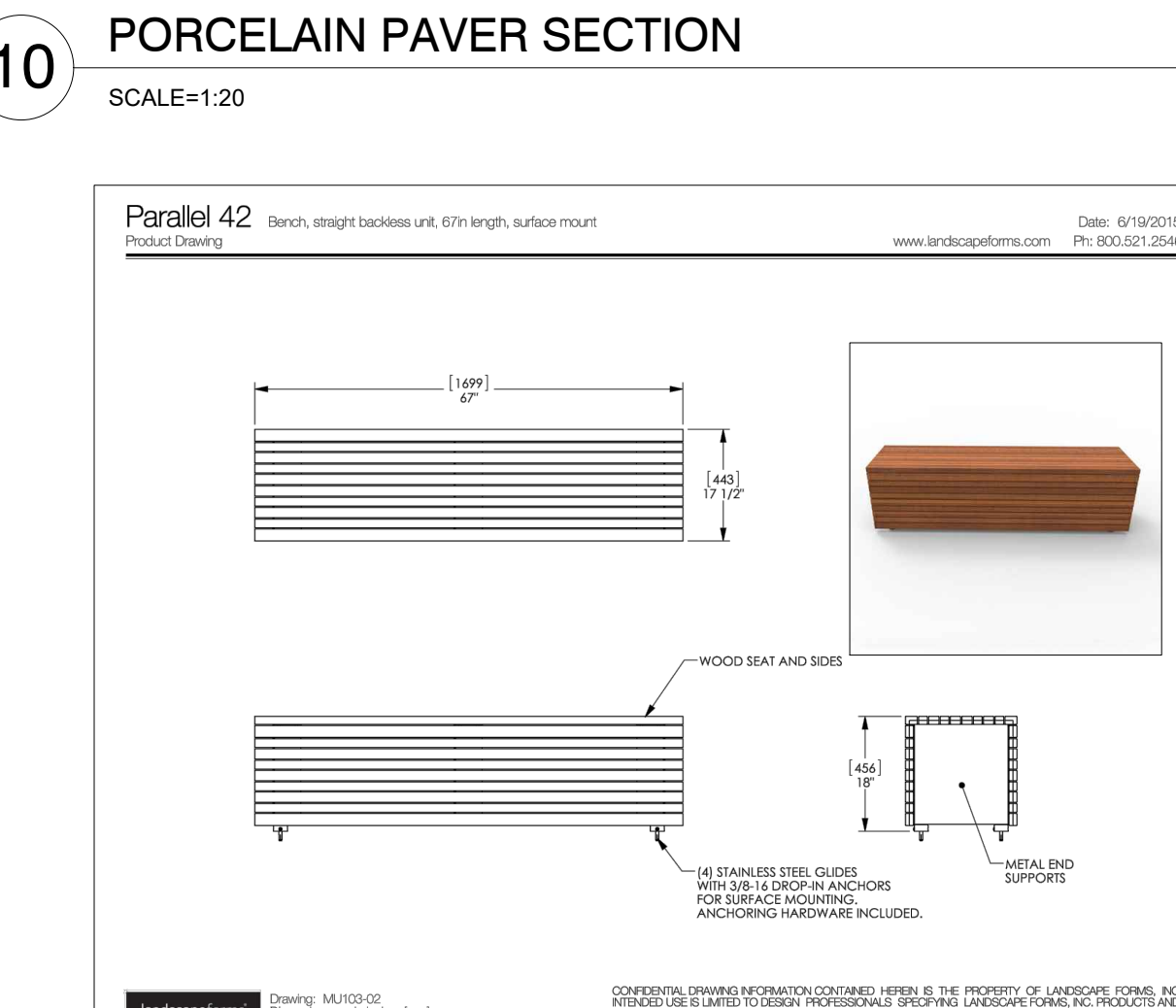

14 BENCH
SCALE: N.T.S.

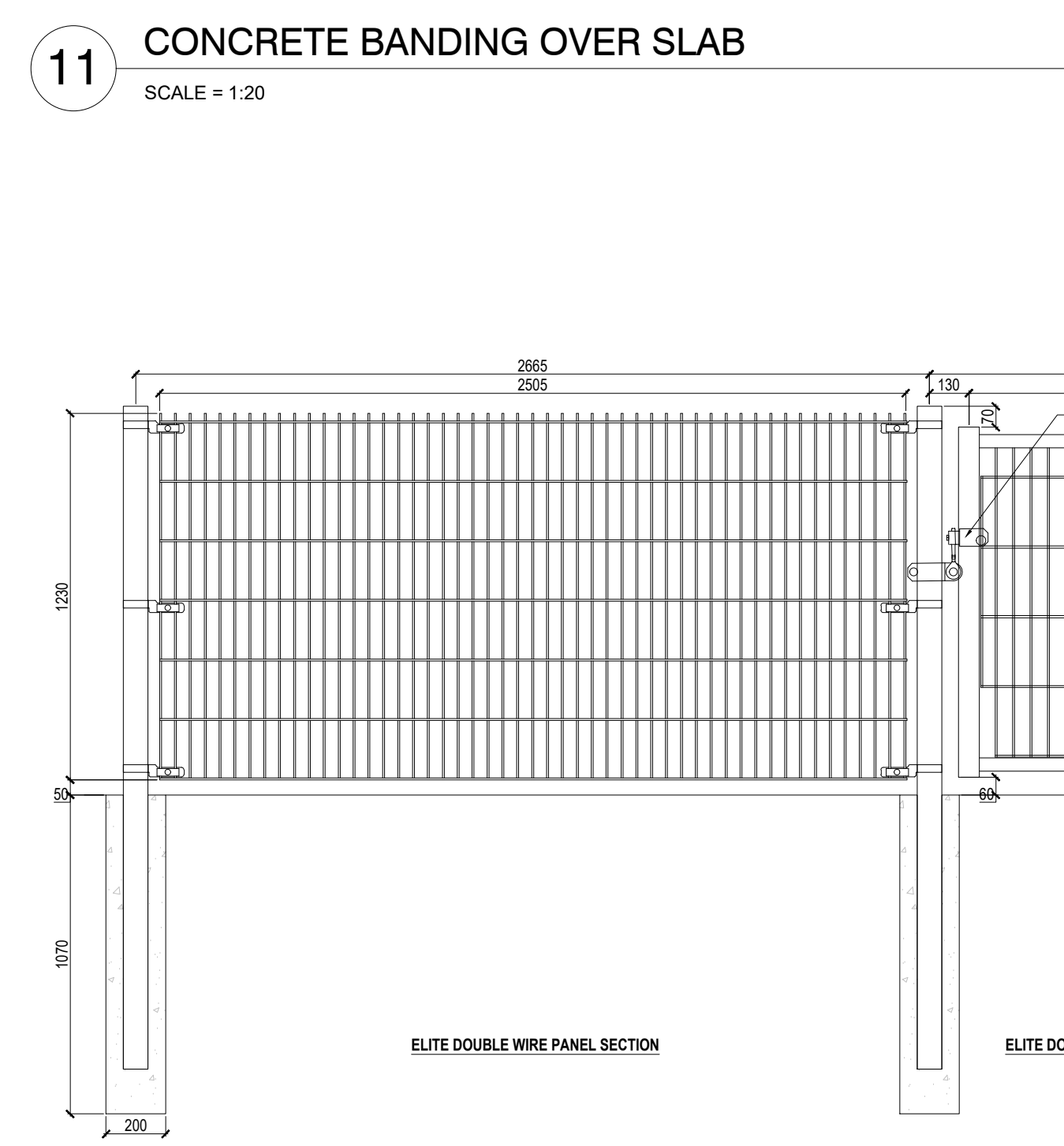

15 FENCE & GATE - OMEGA II
SCALE: N.T.S.

no.	revision	date	by
3	ISSUED FOR ZBA	2025-01-31	RR
2	ISSUED FOR ZBA	2025-01-16	RR
1	ISSUED FOR ZBA	2022-05-06	RR

CONTRACTOR MUST VERIFY ALL DIMENSIONS ON THE JOB AND REPORT ANY DISCREPANCY TO THE LANDSCAPE ARCHITECT BEFORE PROCEEDING WITH THE WORK. ALL DRAWINGS AND SPECIFICATIONS ARE INSTRUMENTS OF SERVICE AND THE PROPERTY OF THE LANDSCAPE ARCHITECT WHICH MUST BE RETURNED AT THE COMPLETION OF THE WORK. ALL DRAWINGS TO BE USED FOR CONSTRUCTION ONLY WHEN SIGNED BY THE LANDSCAPE ARCHITECT.

signed _____ date _____

STUDIO tla

20 Champian Blvd. Suite 102 - Toronto ON - M3H 2T1 info@studiola.ca www.studiola.ca

Systeme de Clôtures Omega II Tel: 450-686-6000 1-800-836-6342
1735 boul. St-Elzear Ouest Fax: 450-681-7905
Laval, Québec www.omegadesux.com
HTL 3N6

CLIENT: 1755 PICKERING PARKWAY

PROJECT: PICKERING, ONTARIO

LANDSCAPE DETAILS

DRAWING: RR

CHECKED: AS SHOWN

DATE: 2021-03-01

PROJECT NO: 20-175

LD-101

ASSOCIATION OF LANDSCAPE ARCHITECTS MEMBER

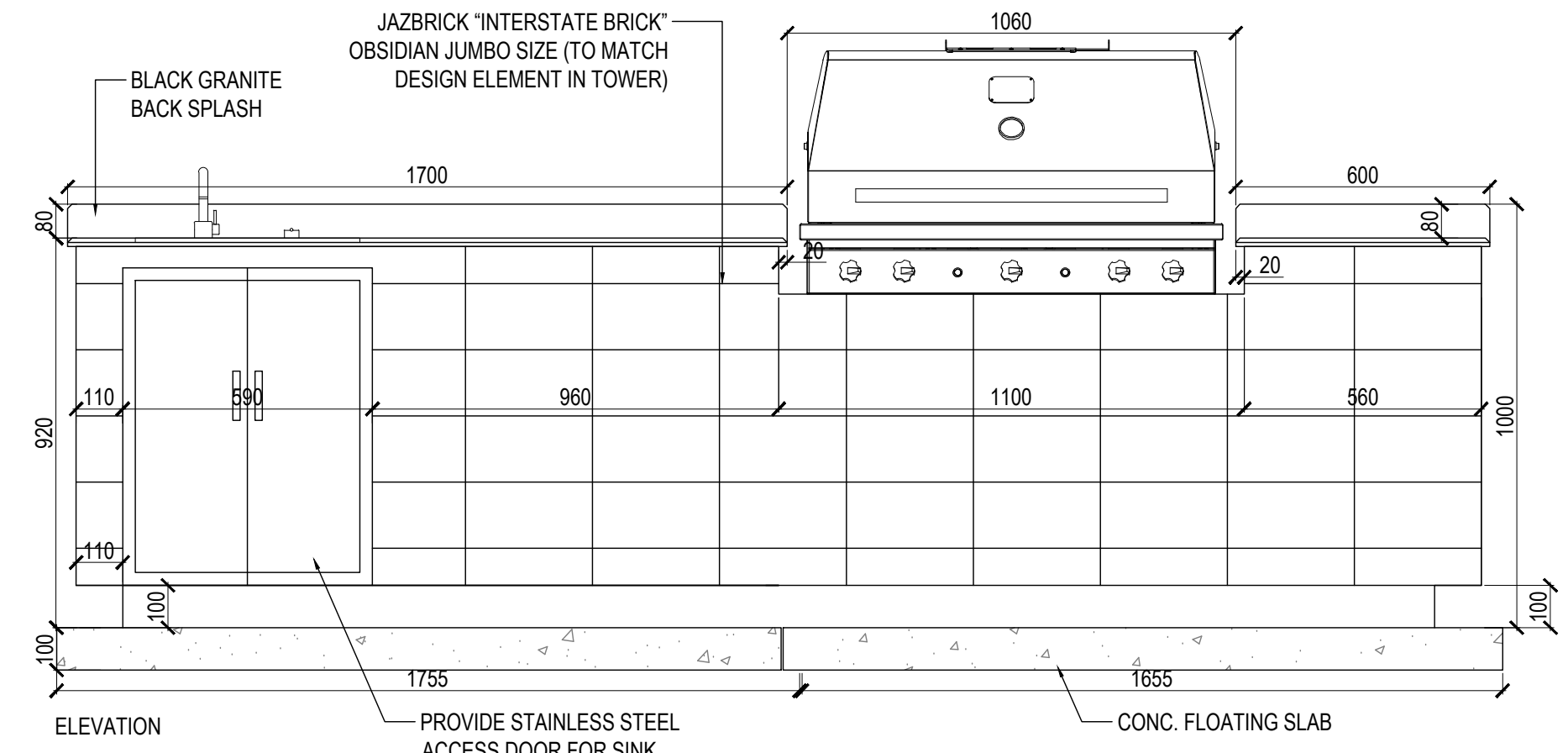
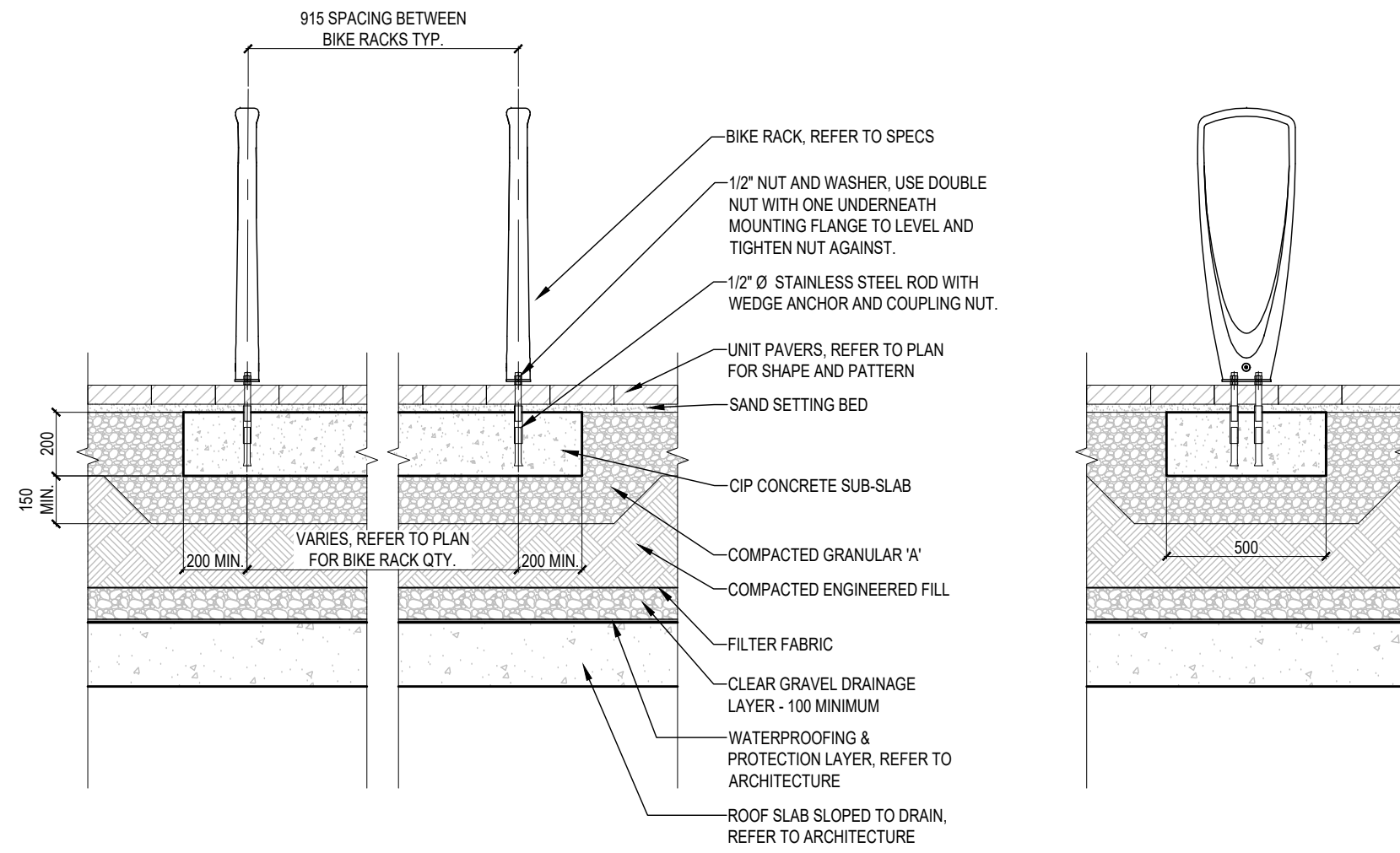
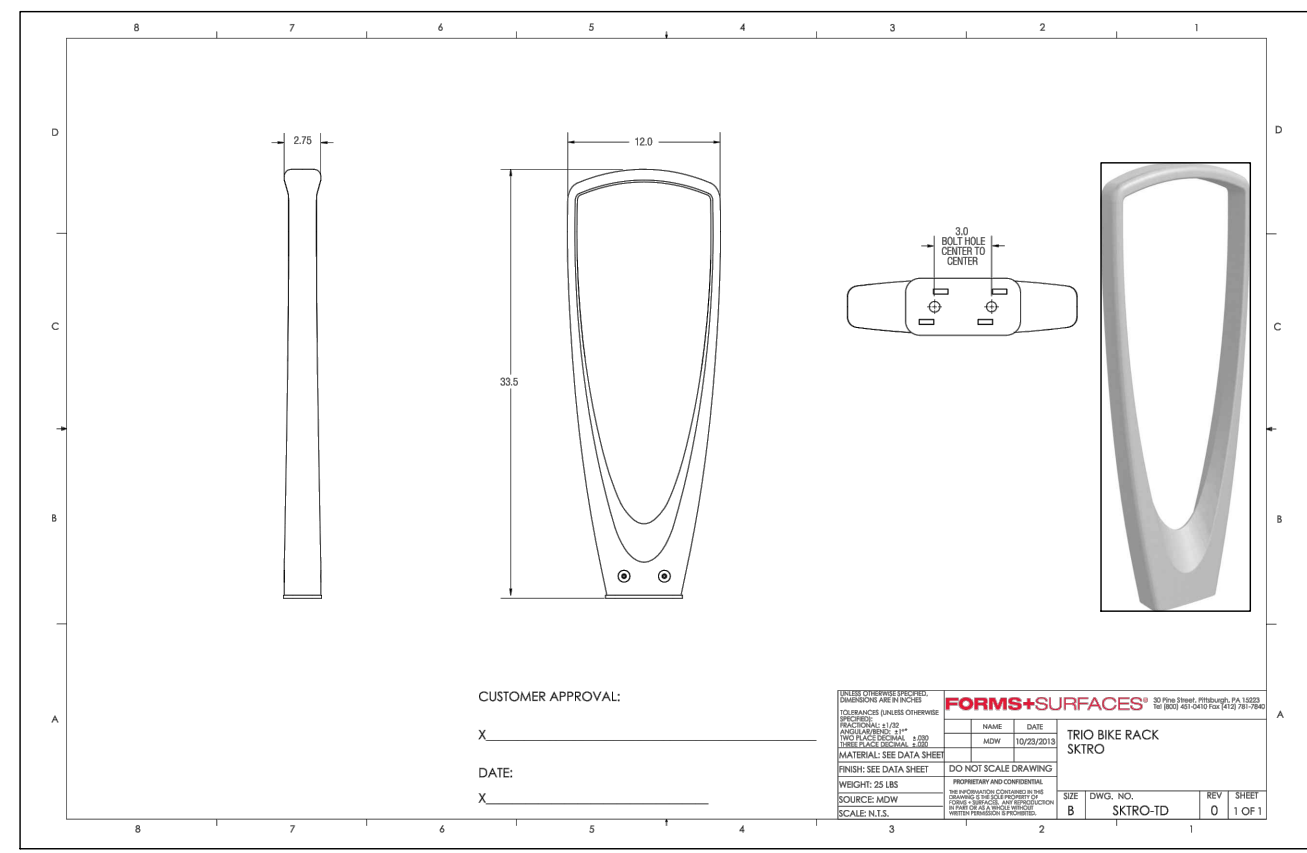

1 BIKE RACK
N.T.S.

2 BIKE RACK
1:20

P-2020-20.175-37

3 BBQ STATION
SCALE 1:15

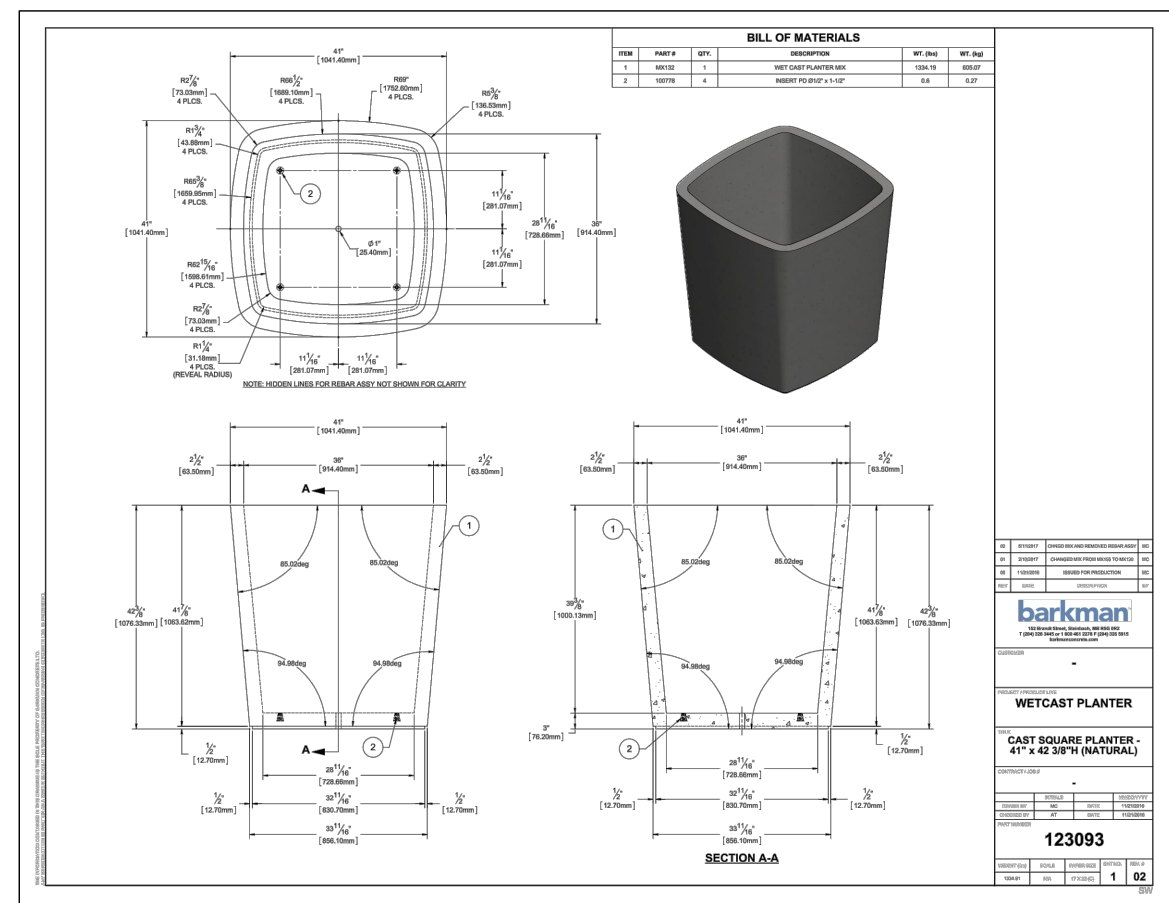

4 BARKMAN LARGE PLANTER
N.T.S.

no.	revision	date	by
3	ISSUED FOR ZBA	2025-01-31	RR
2	ISSUED FOR ZBA	2025-01-16	RR
1	ISSUED FOR ZBA	2022-05-06	RR

CONTRACTOR MUST VERIFY ALL DIMENSIONS ON THE JOB AND REPORT ANY DISCREPANCY TO THE LANDSCAPE ARCHITECT BEFORE PROCEEDING WITH THE WORK. ALL DRAWINGS AND SPECIFICATIONS ARE INSTRUMENTS OF SERVICE AND THE PROPERTY OF THE LANDSCAPE ARCHITECT WHICH MUST BE RETURNED AT THE COMPLETION OF THE WORK. ALL DRAWINGS TO BE USED FOR CONSTRUCTION ONLY WHEN SIGNED BY THE LANDSCAPE ARCHITECT.

signed _____ date _____



20 Champian Blvd. Suite 102 - Toronto ON - M3H 2Z1 info@studiot1a.ca www.studiot1a.ca

CLIENT
1755 PICKERING PARKWAY

PICKERING, ONTARIO

PROJECT
LANDSCAPE DETAILS

DRAWING
DRAWN: RR
CHECKED:
SCALE: AS SHOWN
DATE: 2021-03-01
PROJECT NO: 20-175

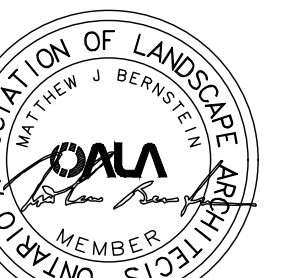

SHEET NO. LD-102